

INSTRUCTION BOOK

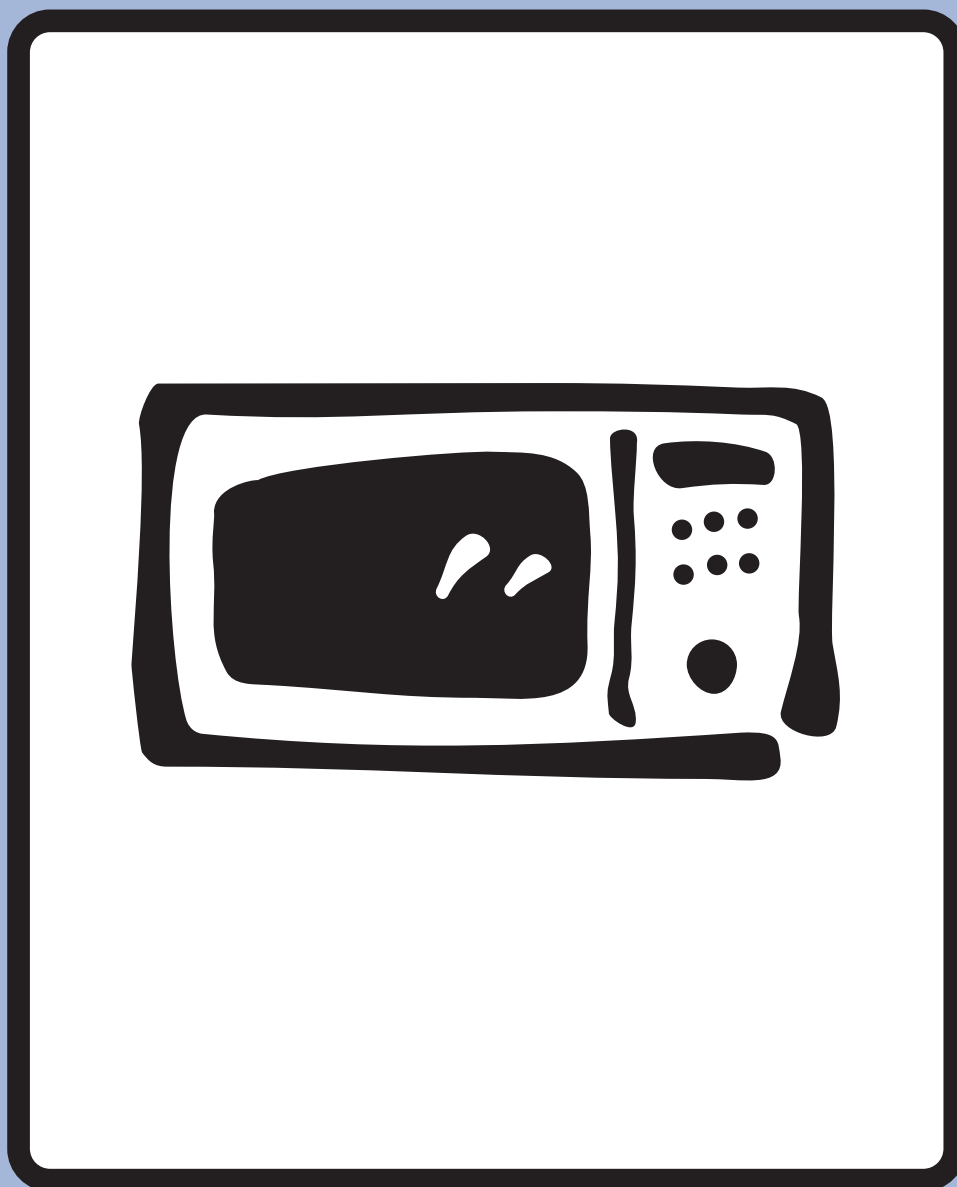

Model EMS 2185

Contents

For the user

Before using your microwave oven 4

Safety Instructions 5

Utensil safety	5
Testing suitability of cookware	5
Foil containers	6
Food safety	6
Safety instructions when cooking by Grill	7
Oven utensils and accessories guide	8

Description of the microwave oven and accessories

The microwave oven	9
Accessories	10
Control panel	11

Before using your microwave oven for the first time

Cleaning	12
Setting the clock	12
General operating instructions	13

How to operate your microwave oven

Microwave cooking	15
Microwave setting guide	16
Minute timer with alarm	16
Grill cooking	17
Microwave and Grill cooking	18
Automatic programmes	19
Auto Defrost	19
Automatic Cooking Programmes	21
Combination cooking Microwave and Grill	22
Quick Start	22
Child Lock	23

Microwave Hints 23

Charts

Defrosting	24
Cooking vegetables	26
Cooking fish	26
Grilling table	27
Combined Microwave and Grilling table	27

Care and cleaning 28

Care and cleaning (grill)	28
Cleaning the accessories (turntable, support and rack)	28
Cleaning the interior	28
Cleaning the exterior	28

Service and spare parts 29

Guarantee conditions

Standard guarantee conditions	30
Exclusions	30

For the installer

Installation

Electrical connections	31
Connecting to the mains	32
Build-In model	32
Technical data	32
Electrolux Service Force	33

Before using your microwave oven

Read through the instruction manual carefully. In order that you can get the best from your new Electrolux microwave oven, the following instructions have been prepared. Please make sure you read them carefully.

It is important that this instruction book is retained with the appliance for future reference. Should the appliance be sold or transferred to another owner, or if you move house and leave the appliance, always ensure that the book is supplied with the appliance so that the new owner can become acquainted with the

functioning of the appliance and the relevant warnings. Please ensure you have read the whole instruction book before using the appliance and that you follow the recommendations given.

Unpacking

N.B. When you unpack the oven, check that the product is free from damage. Damage or any missing parts must be reported immediately to the retailer. The oven, parts of the oven or the accessories may be

wrapped by a protection foil. If so, you must remove this foil before using the oven. Do not leave packing material so that small children can play with it. This can be hazardous.

Safety instructions

- The built-in safety interlock switches prevent the microwave oven from operating when the door is open.
- Do not tamper with them, or attempt to operate the oven with the door open as open door operation can result in exposure to microwave energy.
- Do not allow food spills or cleaner residue to accumulate on door sealing surfaces. See the Cleaning and Care section for cleaning instructions.
- It is particularly important that the oven door closes properly and that there is no damage to the: (1) door (warped), (2) hinges and latches (broken or insecure), (3) door seals and sealing surface.

 If the door, hinges/latches or door seals are damaged, the microwave must not be operated until it has been repaired by an authorized service engineer.

 It is hazardous for anyone except factory trained service personnel to service or make adjustments to this oven. Contact your local Electrolux Service Force Center if service should be required.

- Do not remove the outer case, door or control panel at any time. Doing so may cause exposure to extremely high voltage.
- Install or locate this oven only in accordance with 'installation instructions' found in this manual.
- Use the appliance for its intended use as described in this manual. Do not use corrosive chemicals in this appliance. This type of oven is specifically designed to heat, cook, or defrost food. It is not designed for industrial or laboratory use neither for commercial use as this will invalidate the guarantee.
- Do not operate the oven empty. If food or water is not present to absorb the microwave energy, the magnetron tube can be damaged.
- Do not store this appliance outdoors. Do not use this product near water.
- Do not attempt to dry clothing or newspapers in the microwave oven. These items can ignite.
- Do not use the cavity for storage purposes. Do not leave paper products, cooking utensils, or food in the cavity when not in use.

 If smoke is observed, switch off or unplug the appliance and keep the door closed in order to stifle any flames. **Never use water.**

 Only allow children to use the microwave without supervision when adequate instructions have been given so that the child is able to use the microwave in a safe way and understands the hazards of improper use.

Utensil safety

- Most glass, glass ceramic and heat-resistant glassware utensils are excellent for use in the microwave oven. Although microwave energy will not heat most glass and ceramic items, these utensils can become hot as heat transfers from the food to the container. Use oven gloves to remove dishes.

Testing suitability of cookware

- Place the cookware in the microwave along with a glass half full of water. Heat on 850W (100%) for one minute. If the cookware feels hot, you should not use it. If it is just slightly warm, you can use it for reheating but not for cooking. If the dish is room temperature, it is suitable for microwave cooking.
- Paper napkins, wax paper, paper towels, plates, cups, cartons, freezer wrap and cardboard are great convenience utensils. Always be sure containers are filled with food to absorb energy and thus avoid the possibility of overheating.
- Many plastic dishes, cups, freezer containers and plastic wraps may be used in the microwave oven. Follow manufacturer's instructions when using plastics in the oven. Avoid using plastic utensils with foods that have high fat or sugar content since these foods reach high temperatures and could melt some plastics.
- Do not leave the oven unattended, heating or cooking food in plastic, paper or other combustible containers. If smoke is observed, keep door closed, switch the oven off or disconnect oven until smoke stops.

- Metal containers and containers with metallic trim should not be used in the microwave oven, unless specifically recommended for microwave use.
- Containers with restricted openings, such as bottles, should not be used for microwave cooking.
- Use caution when removing a lid or cover from a dish to avoid steam burns.

Foil containers

Shallow foil containers may safely be used to reheat foods in your microwave oven providing the following rules are observed:

1. Foil containers should not be more than 3 cms (1 1/4") deep.
2. Foil lids must not be used.
3. The foil containers must be at least two-thirds full of food. Empty containers must never be used.
4. Foil containers should be used singly in the microwave oven and should not be allowed to touch the sides. If your oven has a metal turntable or cooking rack, the foil container should be placed on an upturned ovenproof plate.
5. Foil containers should never be re-used in the microwave oven.
6. If the microwave oven has been in use for 15 minutes or more, allow it to cool before using it again.
7. The container and turntable may become hot during use, take great care when removing either from the oven. It is advisable to use an oven cloth or glove when doing so.
8. Remember when using an aluminium foil container that the reheating or cooking times may be longer than you are used to, always ensure that the food is piping hot before serving.

Food safety

- Do not heat food in a can in the microwave oven. Always remove the food to a suitable container.
- Deep fat frying should not be done in the microwave oven, because the fat temperature cannot be controlled, hazardous situations can result.
- Popcorn may be prepared in the microwave oven, but only in special packages or utensils designed specifically for this purpose. This cooking operation should never be unattended.
- Pierce foods with non-porous skins or membranes to prevent steam build-up and bursting. Apples, potatoes, chicken livers, and egg yolks are examples of items that should be pierced.
- The contents of feeding bottles and baby food jars are to be stirred or shaken and the temperature is to be checked before consumption, in order to avoid burns.



When heating liquids, e.g. soups, sauces and beverages in your microwave oven, overheating the liquid beyond boiling point can occur without evidence of bubbling. This could result in a sudden boil over of the hot liquid. To prevent this possibility the following steps should be taken:

1. Avoid using straight-sided containers with narrow necks.
2. Do not overheat.
3. Stir the liquid before placing the container in the oven and again halfway through the heating time.
4. After heating, allow to stand in the oven for a short time, stirring again before carefully removing the container.





Some products such as whole eggs and sealed containers – for example, closed glass jars – may explode and should not be heated in this oven. Occasionally, poached eggs may explode during cooking. Always pierce the yolk, then cover and allow the standing time of one minute before removing cover.

Keep these instructions!

Safety instructions when cooking by grill

1. The glass viewing window may break if water is spilled on it during grilling.
2. Be sure to use an oven glove when loading and unloading the oven. Containers get very hot in the oven, so be careful not to burn yourself. The turntable and metal rack also get very hot so be sure to use an oven glove when handling them.
3. Do not touch the inner or outer viewing window with metal components when loading or unloading the oven. The inside of the door and oven get very hot so take care when attending food in the oven.
4. Do not put the turntable or containers in cold water or try to cool them quickly after use.
5. Do not place items on top of the cabinet. The top of the cabinet gets very hot, so anything placed on it may be damaged by the heat.

 It is quite normal for steam to be emitted around the door, or for misting to occur on the door, or even for water droplets to appear below the door during the cooking cycle. This is merely condensation from the heat of the food and does not affect the safety of your oven. The door is not intended to seal the oven cavity completely.

-  • Do not force the turntable to rotate by hand. This may cause malfunctioning.
- Arcing in the oven during microwave operation usually occurs from use of metallic utensils. Continuous arcing, however, can damage the unit. Stop the programme and check the utensil.
 - Care should be taken not to obstruct any air vents located on the top, rear, side and bottom of the oven.

Do not use this oven for commercial purposes. This oven is made for domestic use only.

Oven utensils and accessories guide

A variety of utensils and materials may be used for cooking in your microwave oven. For your safety and to prevent damaging utensils and your oven

choose appropriate utensils and materials for each cooking method. The list below is a general guide.

Material	Utensils	Microwave Cooking	Grill Cooking	Microwave and Grill cooking
Ceramic & Glass	Corning ware	YES	YES	YES
	Heat resistant glass ware	YES	YES	YES
	Glass ware with metal decoration	NO	NO	NO
	Lead crystal glass	NO	NO	NO
China	Without metal decoration	YES	YES	YES
Pottery		YES	YES	YES
Plastic	Microwave oven heat-proof wear	YES	NO	NO
	Plastic wrap	YES	NO	NO
Metal	Metal baking pan	NO	YES	NO
	Aluminium foil*	YES	YES	YES
Paper	Cups, plates, towels	YES	NO	NO
Waxed paper		YES	NO	NO
Wood		NO	NO	NO
Accessories	Grill rack	NO	YES	YES
	Turntable	YES	YES	YES
	Turntable support	YES	YES	YES

YES: Utensils and accessories to use NO: Utensils and accessories to avoid

*NOTE: Use aluminium foil only for shielding purposes, overuse may cause arcing.

Description of the microwave oven and accessories

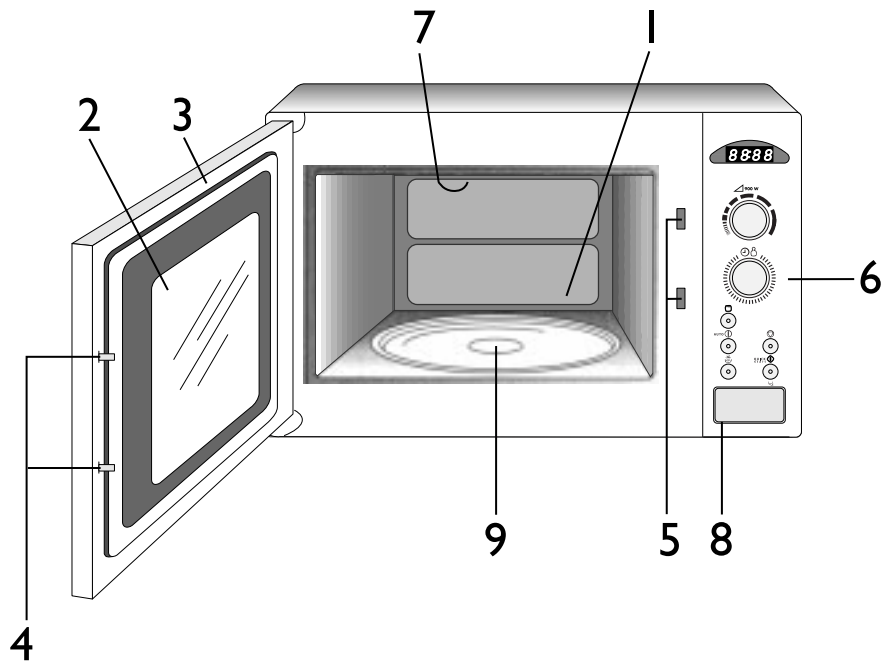

The microwave oven

- 1 Cooking compartment.
- 2 Viewing window.
- 3 Oven door.
- 4 Door catch.
- 5 Safety interlock system.
- 6 Control panel.
- 7 Grill element.
- 8 Door open button.
- 9 Drive shaft for turntable.

Accessories

Turntable and turntable support

The turntable and turntable support should be installed as shown in the diagram. Take care to ensure the turntable support is properly in place.

The turntable may turn clockwise or counterclockwise during operation. Do not rotate the turntable manually, as you could damage the drive system.

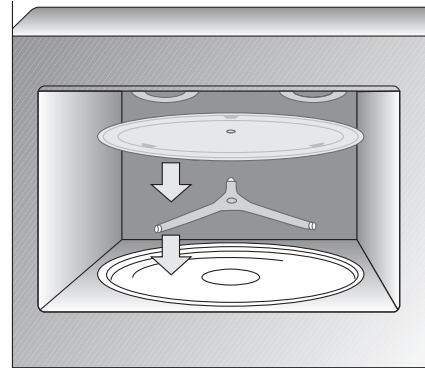

Rack

For the use with the **grill** function, to brown shallow dishes. It has to be positioned on the center of the turntable.

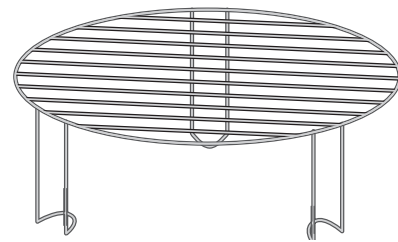

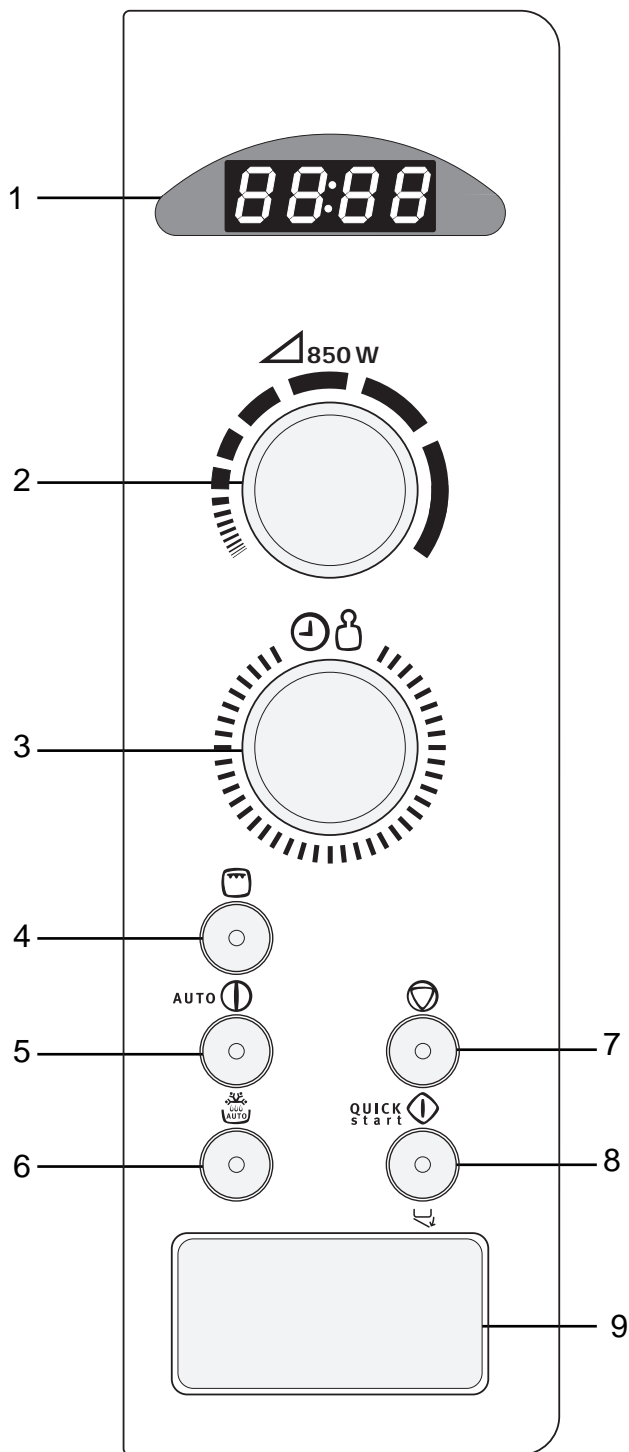

Control panel

1. Display window – showing time of day, cooking time and weight.
2. Power knob – for desired microwave power level.
3. Timer knob – to select cooking time or weight.
4. Grill.
5. Auto – for Automatic cooking programmes.
6. Auto Defrost by weight.
7. Stop/Clear – to cancel or interrupt a cooking programme.
8. Start – to start desired programme and to start the Quick start programme.
9. Door open.

Before using your microwave oven for the first time

Cleaning

Wipe over the front of the appliance with a damp cloth. Do not use abrasive cleaning agents (these can damage the surface). For stainless steel fronts use a suitable stainless steel cleaning agent that leaves a protective film against fingerprints.

Before you first use the appliance, remove all the accessories (including the turntable and turntable support) from the cooking area. Wash the accessories in warm water and washing up liquid. Wipe the cooking space with a soft, damp cloth.

Setting the clock

Plug the appliance into the mains. The display starts to flash "00:00"

The dots between the digits will flash rapidly.



Example: To set 12:15:

Set the time of day with the Timer knob.



The dots between the digits flash slowly.

Confirm by pressing either the Start-button or the Clear button.



The time of the day is displayed.

12:15

The appliance is now ready for use.



To reset the time of day, once the microwave is operational;

Press and hold the Clear key for 5 seconds, the dots between the digits will flash rapidly.

Set the time of day with the Timer knob and press the Clear or Start key to confirm.

The dots between the digits stop flashing.

The time of day has been reset.

General operating instructions

Action	Comments
1. Press door open button.	The door opens and the interior light switches on.
2. Place food in the cooking space.	
3. Shut the door.	An audible click will be heard when the door is shut. If the door is not shut properly the appliance will not function.
4. Select the cooking functions and time according to the instructions given in the following pages.	Turn the timer knob clockwise to increase and counterclockwise to decrease time.
5. Press the Start-button.	The appliance starts. The display shows the selected cooking time, and counts down in seconds. When grilling, the signal light representing this operating mode lights up.
6. End of cooking sequence.	The end of the cooking sequence is indicated by an audible tone. The appliance and the interior light will switch off. The time of day appears in the display.

i If the oven is not started within 4 minutes, the settings are automatically cancelled and the time of day reappears in the display.

i If maximum cooking time setting "60:00" is exceeded during the setting, the display shows "00:00".

Action	Comments
1. Interrupting the cooking process (e.g. for stirring): Open the door by pressing the door button.	The cooking operation stops. In the display, the two dots between the digits flash. The selected settings are unaffected.
2. Shut the door and press the Start button.	The countdown will continue.
3. Cancelling the programme : Press the Clear button.	The cooking process is cancelled. The appliance and the interior lighting switch off. Time of day is displayed.
4. Modifying the selected cooking time: turn the Timer knob clockwise or counter-clockwise.	The cooking time in the display changes.
5. Modifying the selected microwave power: Rotate the Power knob.	The new power setting is displayed for 5 seconds. The cooking process continues with the new power setting.
6. Operating of the grill: Press the Grill button.	"GRILL" and "ONLY" are displayed successively for 0,5 seconds each. When working with grill and microwave power (e. g. 850 W), "GRILL" and the chosen microwave power (850) are displayed successively for 0,5 seconds each.



If the new selection reaches "00:00" in the display, the cooking time is over and an audible signal will be heard. The appliance and the interior lighting switch off. During a cooking process, the cooking time can be increased to a maximum of 60 minutes.

How to operate your microwave oven

Microwave cooking

This basic microwave cooking method allows you to cook food for a desired time. In addition to the maximum power level, you can select 9 different microwave power levels, 80W to 850W.

Foods with high moisture content should be cooked on maximum power, as this is the fastest cooking method and maintains the natural flavour and texture of the foods.

Example: To cook at 850W for 1 min 15 s :

1. Set the required microwave power by turning the Power knob.

The time of day disappears from the display and the selected microwave power appears.

Turn to the left = lower power

Turn to the right = higher power



850

2. Set the required cooking time by turning the Timer knob. The chosen time appears in the display.



01:15

3. Press the Start button.

The selected time starts to count down.



01:14



Cooking time can be set as follows:

from 0 to 2 min in 5 second steps

from 2 to 5 min in 10 second steps

from 5 to 10 min in 20 second steps

from 10 to 20 min in 30 second steps

starting from 21 min in 1-min steps

Maximum programme length is 60 minutes.



Metal items must be kept at least 2 cm from the oven sides and the oven door.



Microwave setting guide

850W	– heating liquids
700W	– to start roasting, stewing, etc. – cooking vegetables – cooking dishes
600W	– defrosting and heating of deep frozen ready made meals
500W	– heating refrigerated ready made meals – finish cooking casseroles – cooking egg based dishes
450W	– finish cooking casseroles
350W	– cooking of delicate dishes
250W	– heating baby food in glass jar – soaking rice – heating delicate dishes – melting of gelatin
150W	– defrosting meat, fish and bread
80W	– defrosting cheese, cream and butter – defrosting cakes with cream or butter icing – to let dough rise – warming cold dishes, drinks, softening butter

Minute timer with alarm

The minute timer with alarm can also be used as a general purpose reminder. The timer works without selecting a cooking function.







How to set:

1. Select the microwave power " 850W " using the Power knob (all the way to the left) and ensure the grill is off. 
2. Set the required time with the Timer knob. The time of day disappears from the display and the selected length of time appears. 
3. Press the Start button. The pre-set time will start to count down. An audible signal will sound when the timer has finished counting down. 

Grill cooking

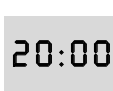
This method is ideal for toasting bread or muffins.
Remember the oven will be hot, always use oven gloves. Place shallow dishes on grilling rack.
Cooking time can be set to a maximum of 60 minutes.

Example: Set oven to Grill for 20 minutes with Grill:

- | | | |
|--|---|--|
| 1. Turn the Power knob until reaching "0".
The time of day disappears. |  |  |
| 2. Set the required grilling time by using the Timer knob. |  |  |
| 3. Press the button for the grill function. The signal light for grill comes on. GRILL and ONLY appear alternatively in the display. |  |  |
| 4. Press the Start button. The pre-set time will start to count down. |  |  |
-





If you press the grill button while grilling, the oven turns off. The clock time appears in the display.



Microwave and Grill cooking



This function allows you to combine the advantages of the speed and convenience of a Microwave with the browning and crisping benefits of a Grill.

Example: Set Microwave and Grill Cooking using Grill with Microwave power 850W for 20 minutes:

1. Set the required microwave power output using the Power knob. 

The time of day disappears from the display. The selected microwave power appears in the display (in watts). 
2. Set the required time using the Timer knob. 

3. Press the button for Grill function. 



GRILL and **850** appear alternatively in the display. The signal light comes on.  
4. Press the Start button, The pre-set time will start to count down. 









If you press the grill button while grilling, the grill turns off and the signal light for grill goes off. The appliance functions in microwave mode only.

Automatic Programmes

Programmes for defrosting  and cooking  are available. After having selected the programme, merely enter the weight of the dish, the rest of the programming is done automatically. The following gives you an overview of what food can be defrosted, cooked or combination cooked with which programme.

Auto Defrost

The Auto Defrost by Weight feature is an accurate defrosting method for frozen meat, poultry, or fish.







Progr.	Food categories	Examples	Weight from – up to
	Poultry ¹	Poultry (whole or portions)	100 – 2000 g
	Meat	Pork roast, Goulash	100 – 2000 g
	Fish	Fish (whole or fillets)	100 – 1000 g
	Delicate cakes and pastries	Cream pie	100 – 1000 g

¹ Cover legs and wings with aluminium foils before defrosting.

 Unpack the frozen dish, place on top of a small overturned dish set inside a larger one to hold the liquid from defrosting. Follow our recommended standing time (general rule: standing time = defrosting time). A triple beep will sound halfway through defrost time. Turn or mix dish and, if possible, break up into pieces.

Let the oven cool down for 15 minutes after using the grill if you wish to use an automatic defrost programme.

Example: To defrost a 1.0 kg chicken:

- | | | |
|---|---|--|
| 1. Press the button for Automatic Defrost until  appears in the display. |  |  |
| 2. Use the Timer/weight knob to set the weight. |  |  |
| 3. Press the Start button. The display shows the defrost time. |  |  |
| 4. If you want to modify the settings, press the Clear-button and start again. | | |

i Midway through the programme, three short beeps will be heard. Stir or turn the food item at this time. The programme is not interrupted.

Defrosting Tips

1. It is better to underestimate defrosting time if you are unsure. Food will continue to defrost during the standing time.
 2. Separate food as soon as possible.
 3. Turn large items, e.g. joints, halfway through the defrosting time, or at pause.
 4. Remove any thawed food as soon as possible.
 5. Remove or open any packaging before defrosting.
 6. Place food in a larger container than that which it was frozen in, this will allow for easy stirring.
 7. Begin thawing poultry, breast side down and turn over halfway through defrosting time or at pause. Delicate areas such as wing tips can be shielded with small pieces of smooth foil.
 8. Standing time is very important, particularly for large, dense foods which cannot be stirred to ensure that the centre is completely defrosted before cooking.
-

Manual defrosting

For manual defrosting (without using Auto Defrost features) use 150W. To speed up the defrosting of dense foods over 450g (1lb), the oven may be started on full power for 1–3 minutes, then be reduced to 150W until defrosting is complete.

Automatic Cooking Programmes

Progr.	Food categories	Examples	Weight from – up to
C1	Fresh vegetables I	Brussels sprouts, cabagge, carrots, celeriac	100 – 1000 g
C2	Fresh vegetables II	Corgettesi, leeks, potatoes, spinach, fennel, cauliflower, broccoli	100 – 1000 g
C3	Frozen vegetables	Carrots, cauliflower, Brussels sprouts, leeks, corgettes, spinach, broccoli	100 – 1000 g







Cook covered, in a heat-resistant glass dish, whenever possible. A triple beep rings halfway through cook time. If cooking over 500 g of vegetables, stir once or twice.

Please add water in the following amounts:

- for fresh vegetables (I+II): 100 – 500 g: 3 – 6 tablespoons / 500 – 1000 g: 9 – 12 tablespoons.
- for frozen vegetables: 100 – 500 g: 3 – 9 tablespoons / 500 – 1000 g: 9 – 15 tablespoons.

Example: To cook 500 g Fresh Vegetables I:

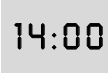
1. Press the button for Automatic Cooking programme until **C1** appears in the display.  
2. Use the Timer/weight knob to set the weight.  
3. Press the Start button.  
The display shows the time.

Combination cooking Microwave and Grill

Progr.	Food categories	Weight from – up to	Comments
GG1	Chicken ¹ (fresh) Chicken in pieces	200 – 2000 g	If cooking a dish weighing over 500 g, 3 beeps remind you to turn the food halfway through the cooking time.
GG2	Pork roast ² (fresh)	400 – 1200 g	See above.
GG3	Gratin ³	200 – 2000 g	If cooking a dish weighing 200 – 500 g, you should place the dish on the grill rack.

i ¹ If cooking a weight from 1000 – 1400 g, please use a deep heat-resistant dish, directly on the turntable, do not cover. Set chicken pieces directly on the rack.

² The pork roast should be cooked in a deep heat-resistant dish, set directly on the turntable. Do not cover.

³ Enter the total weight of the dish.

The automatic cooking times are calculated for foods at +5° C (e.g. refrigerated foods)

The weight can be set as follows:

– from 100 to 1000 g in 25 g-steps,

– from 1000 to 2000 g in 50 g-steps.

For all dishes not covered by automatic programmes, enter manually microwave output power and time according to cook tables.

Quick Start

How to set

The Quick Start function provides full microwave power from 30 seconds up to 2 minutes and 30 seconds, in 30 second intervals.

Example: Heating a cup of water (1 min 30 s):

1. Press the Start/Quick button three times.

The time appears in the display and the appliance starts to work.



01:30

2. You may increase the time by 30 second intervals while the programme is running up to a limit of 2 minutes and 30 seconds by pressing the Start/Quick button.

Child lock

This oven is equipped with a Child Lock Safety feature to prevent accidental operation by children.

How to set :

First press the Clear button **5 times**, then press the Start button. The display shows "LOC".



LOC

The safety lock prevents the oven from operating. There will be no effect if you turn either knob or any button.

How to cancel :

Press the Clear button **5 times**, then press the Start button. A beep will sound then. The time of the day will appear in the display again and the appliance will function as normal.



Microwave Hints

- Always keep the oven clean – avoid spill-overs and do not forget to clean under the glass tray and the inside of the door.
- Preferably use round or oval casseroles with a lid when cooking in your microwave oven.
- Do not use metal or metal decorated casserole dishes. Certain plastic materials can melt and be warped by hot food.
- Cover the food when cooking. Use a glass lid, a plate or grease proof paper.
- Pastry, bread and the like can be defrosted directly in a bread basket or on a paper towel.
- If frozen food is heated in its packaging, the packaging should be opened. Packaging containing metal or metal decoration must not be used unless specifically recommended for use in the microwave. Remove metal clips and wire ties.
- Smaller pieces of aluminium foil can be used to cover parts that easily overcook such as chicken legs.
- Food with peel or skin should be pierced with a fork – e.g. potatoes and sausages. Do not boil eggs in the microwave oven as they can explode.
- Put large, thick pieces close to the edge of the casserole and try to cut the food in to even-sized pieces. Always place the food in the centre of the oven.
- The food will be more evenly cooked if you stir or turn it regularly.
- Always set a shorter cooking time than indicated in your recipe to avoid overcooking. The larger the amount of food the longer it takes.
- Use little or no water for vegetables.
- Use less salt and spices than for 'normal' cooking.
- Season afterwards.
- Allow a few minutes 'standing' time after the oven has switched off to ensure complete and even cooking results.
- Always ensure food is piping hot throughout before serving.
- Use gloves when taking dishes and food from the oven.

Charts

Defrosting

Dish	Weight (in g)	Power (Watt)	Duration (min)	Standing time (min)	Remarks/Hints
Meat					
Whole meat	500	150	11–15	10–15	Turn once. Cover fatty parts with aluminium foil midway through.
Steak	200	150	5–7	5–10	Turn once.
Mixed chopped meat	500	150	10–15	5–10	Remove defrosted chopped meat midway through programme.
Poultry					
Chicken	1000	150	20–30	15–30	Turn once. Cover legs and wings with aluminium foil midway through.
Duck	1500–2000	150	30–50	40–60	As for chicken.
Fish					
Whole fish	500	150	11–13	15–20	Turn once. Cover fins with aluminium foil.
Shrimps/Crab	250	150	6–8	15–20	Stir thoroughly after half the defrosting time.
Dairy produce					
Cottage cheese	500	150	18–25	15–20	Remove any aluminium foil wrapping. Divide and stir frozen pieces from time to time.
Butter	250	150	2–5	15–20	Remove any aluminium foil wrapping.
Cheese	250	150	3–5	20–30	Turn once.
Cream	200 ml	150	7–10	15–20	Remove any aluminium foil wrapping. Stir frozen from time to time.
Fruit					
Strawberries	500	80	14–16	10–15	Defrost in a covered container, turn once.
Cherries	250	80	7–9	5–10	As for strawberries.
Black currants	250	80	8–10	10–15	As for strawberries.
Red currants	250	80	7–9	5–10	As for strawberries.

Defrosting

Description	Weight (in g)	Power (Watt)	Duration (min)	Standing time (min)	Remarks/Hints
Bread					
Rolls (50 g)	4 units	150	3–5	3–5	Set on a paper towel, turn once.
Whole meal, mixed, rye Loaf	1 slice (60–80 g) 500	150 150	1–2 20–25	3–5	Defrost in a covered container. Cover cutting surface.
Pastry					
Dry cakes e.g. cakes with short crust pastry	300	80	4–8	30–40	Set on a paper towel, cover.
Fruit flans baked on a baking sheet	400–450	80	6–12	5–10	As for dry cakes.
1 slice cheese cake	400	80	6–12	5–10	As for dry cakes.
1 slice covered apple tart	400	80	6–12	5–10	As for dry cakes.
Cream and butter- cream layer cakes	300–400	80	4–8	10–20	Begin defrosting of cakes in the appliance, then remove.
Melting food					
Chocolate/toppings	100	850	2–4		Break up into pieces, stir from time to time.
Butter	50	850	1/2–1		To warm set time for 30 s longer.
Heating of refrigerated food and drink					
1 jar baby food	125–250	450	1/2–2	2–3	Heat jar without lid. Stir after warming. Check temperature.
1 ready meal on a plate	350–400	850	3–5	2–3	Heat in a covered container. Place gravy alongside in a cup.
1 portion of meat	150	850	1–2	2–3	All meat, except breaded meat, should be heated in a covered container.
1 portion vegetables, potatoes or rice	200	850	2–3	2–3	Heat in covered container, stir once.
1 cup soup	200 ml	850	2–3	2–3	Heat clear soup uncovered, cover thick soups. Stir.
Drinks					
Milk or baby food	200 ml	850	1/2–1	2–3	Remove any lids. Stir after warming!
Boil 1 cup water	180 ml	850	1/2–2	2–3	Stir instant coffee or tea when the water has stopped boiling.
1 cup milk	200 ml	850	1	2–3	Heat milk till it is just hot enough to drink. Stir.
1 cup coffee (reheat)	200 ml	850	1/2–1	2–3	Stir. Check temperature!

Description	Weight (in g)	Power (Watt)	Duration (min)	Standing time (min)	Remarks/Hints
Defrosting and heating of frozen convenience foods					
1 portion meat with gravy	150	850	3–5	2–3	Heat in a covered container. Stir now and again.
1 portion meat with vegetables, garnish	350–450	850	7–12	2–3	As for meat with gravy.

Cooking vegetables

Cook all vegetables in a covered container.

Description	Weight (in g)	Liquid added	Power (Watt)	Duration (min)	Standing time (min)	Remarks/Hints
Cauliflower	500	1/8 l	850	9–11	2	Dot with butter.
Frozen broccoli	300	1/8 l	850	8–11	2	Stalks facing outwards.
Mushrooms	250	none	850	4–6	2	Cut into slices.
Frozen peas and carrots	300	1/2 cup	850	8–11	2	
Carrots	250	2–3 tsp	850	8–10	2	Cut into cubes or slices.
Potatoes	250	2–3 tsp	850	4–6	2	Peel and quarter.
Red/Green peppers	250	none	850	4–6	2	Cut into cubes or slices.
Leeks	250	1/2 cup	850	4–6	2	Cut into rings or pieces.
Frozen Brussels Sprouts	300	1/2 cup	850	8–11	2	

Cooking fish

Description	Weight (in g)	Power (Watt)	Duration (min)	Standing time (min)	Remarks/Hints
Fish fillets	500	850	6–8	2	Cook covered. Turn halfway through the cooking time.
Whole fish	800	1. 850	3–4	3	Cover during cooking.
		2. 450	12–14	2	Cover flat parts with aluminium foil.



The times stated here are for guidance only.

Grilling table

Description	Weight (in g)	Accessories	Time (min)
Fish			
Mackerels	600–800	Rack.	18–24
Sardines	6–8 pieces	Rack.	18–20
Meat			
Sausages ¹	6–8 pieces	Rack.	20–26
Frozen chopped meat	2 pieces	Rack	18–20
2 Rumpsteak ¹	400 each	Rack.	20–30
Others			
Toast	4 slices	Rack.	2–3
Toasted snacks	2 slices	Rack.	4–8

¹ First preheat the oven for 2,5 minutes.



The grill temperatures and times given are for guidance only.

Grilling is ideal for flat pieces of meat and fish.

Unless otherwise stated, the settings given in the table are for use in cold oven.

Flat foods should be turned only once. Larger, rounder pieces should be turned more often.

Fish are best placed head to tail on the rack.

Combined Microwave and Grilling table

Description	Weight (in g)	Accessories	Shelf level from base	Microwave power (Watt)	Time (min)
Noodle casserole	500 g noodles	shallow dish	Turntable	250	10–15
Potatoes au gratin	800 g potatoes	shallow dish	Turntable	850	20–25
Lasagne	800 g	shallow dish	Turntable	250	15–20
Meatloaf	500 g	deep dish	Turntable	850	10–12
Onion soup au gratin	2 bowls	soup bowls	Turntable	450	4–6



The ranges of time given are for guidance only, as they depend upon the composition and the size of the item being cooked, as well as the desired finish.

Care and cleaning

The oven must always be clean. Residue of food from spill-overs or splatters will absorb microwave energy causing it to burn on. This could reduce the efficiency of the oven and may cause unpleasant odours. Do not attempt to tamper with or make any adjustments or repairs to any part of the oven. Repairs should only be made by an authorised service engineer.

 Be sure the oven is off or the unit is unplugged before cleaning.

Care and cleaning (grill)

The element may be stained with spattered fat or oil while the oven is in use. Wait until the cavity cools down and wipe off the spattered oil before next use of the oven. Stains on the grill may cause unpleasant odours and smoke.

Cleaning the accessories (turntable, support and rack)

Clean them with mild detergent after removing them from the cavity. The turntable support should be carefully handled.

 The inside of the oven and turntable get very hot, so do not touch them immediately after use.

Cleaning the interior

Soilage that is allowed to remain on the oven walls, door seal and door surface will absorb microwave energy, reduce the efficiency of the oven, and possibly damage the oven interior.

Use mild, liquid detergent, warm water and a soft, clean cloth to remove soilage. **NEVER USE ABRASIVE CLEANERS, COMMERCIAL OVEN CLEANERS OR STEEL WOOL PADS ON ANY PART OF THE MICROWAVE OVEN.**

To loosen difficult soilage, boil a cup of water in the microwave oven for 2 or 3 minutes. **NEVER USE A KNIFE OR ANY UTENSIL TO REMOVE SOILAGE FROM OVEN SURFACES.**

To remove odours from the oven interior, boil a cup of water plus 2 tablespoons of lemon juice for 5 minutes.

Cleaning the exterior

Open the oven door when cleaning the control panel. This will prevent the oven from being turned on accidentally. You should clean outside surfaces of the oven with mild liquid detergent and water followed by a wiping with clear water to remove any excess detergent. Dry with a soft cloth.

Spray-on window cleaners or all purpose spray-on kitchen cleaners can also be used. Never use abrasive cleaners, scouring pads or harsh chemicals on outside surfaces of your oven. To prevent damage to the working parts, do not allow water to seep into ventilation openings.

Service and spare parts

If the appliance does not function correctly, please carry out the following checks before contacting your local Service Force Centre.

If the oven does not come on:

- Check the appliance is connected correctly.
- Check that the oven is plugged in properly.
- Replace the fuse in the plug, if required, with another of the same rating and check that the plug has been wired correctly.
- Check that the socket switch and/or the switch from the mains supply to the oven are ON.
- Check that the socket is receiving power, by plugging in an appliance you know to be working.
- Check that the fuse in the fuse box is intact.

If the microwave does not function:

- The child safety lock may have been set.
- Check the controls are set correctly.
- Check settings/procedures against the instruction booklet
- Check the door closes properly (if food particles or other objects have become stuck inside the door, it will not close properly and microwave cooking will not take place).
- Check the start pad has been depressed.
- If the grill function has been used, the oven may not have cooled sufficiently.

If after carrying out the above checks, the oven still does not function correctly, contact your local Electrolux Service Centre by telephoning:

0990 929929

Your telephone call will be routed to the Service Centre covering your post code area.

The address can be found on the following pages of this instruction book.

IMPORTANT:

If you call out an engineer to a fault listed above, or to repair a fault caused by incorrect use or installation, a charge will be made even if the appliance is under guarantee.

When you contact the service centre they will need the following information:

1. Your name, address and postcode
2. Your telephone number
3. Clear concise details of the fault
4. The model number
5. Date of purchase

We suggest you make a note below so you have the details to hand:

Model: EMS 2185

Serial Number:

Date of Purchase:

In-guarantee customers should ensure the necessary checks have been made as the engineer will make a charge if the problem is not a mechanical or electrical breakdown.

Please note that proof of purchase will be required for in-guarantee calls.

Spare parts

Spare parts may be purchased through your local Service Centre.

Customer care

For general enquiries concerning your Electrolux appliance, or for further information on Electrolux products, please contact our Customer Care Departement by letter or telephone as follows:

Customer Care Department
Electrolux Limited
PO Box 47
Newbury
Berkshire RG14 5XL

Tel: 01635 522799

Guarantee conditions

Standard guarantee conditions

We, Electrolux, undertake that if within 12 months of the date of the purchase this Electrolux appliance or any part thereof is proved to be defective by reason only of faulty workmanship or materials, we will, at our option repair or replace the same **FREE OF CHARGE** for labour, materials or carriage on condition that:

- The appliance has been correctly installed and used only on the electricity supply stated on the rating plate.
- The appliance has been used for normal domestic purposes only, and in accordance with the manufacturer's instructions.
- The appliance has not been serviced, maintained, repaired, taken apart or tampered with by any person not authorised by us.
- All service work under this guarantee must be undertaken by an Electrolux service centre.
- Any appliance or defective part replaced shall become the Company's property.
- This guarantee is in addition to your statutory and other legal rights.

Home visits are made between **8.30am** and **5.30pm** Monday to Friday. Visits may be available outside these hours in which case a **premium** will be charged.

Exclusions

This guarantee does not cover:

- Damage or calls resulting from transportation, improper use or neglect, the replacement of any light bulbs or removable parts of glass or plastic.
- Costs incurred for calls to put right machines improperly installed or calls to machines outside the United Kingdom.
- Appliances found to be in use within a commercial or similar environment, plus those which are subject to rental agreements.
- Products of Electrolux manufacture which are not marketed by Electrolux.

European Guarantee

If you should move to another country within Europe then your guarantee moves with you to your new home subject to the following qualifications:

- The guarantee starts from the date you first purchased your product.
- The guarantee is for the same period and to the same extent for labour and parts as exist in the new country of use for this brand or range of products.
- This guarantee relates to you and cannot be transferred to another user.
- Your new home is within the European Community (EC) or European Free Trade Area.
- The product is installed and used in accordance with our instructions and is only used domestically, i.e. a normal household
 - The electrical supply complies with the specification given in the rating label.
- The product is installed taking into account regulations in your new country.

Before you move, please contact your nearest Customer Care centre, listed below, to give them details of your new home. They will then ensure that the local Service Organisation is aware of your move and able to look after you and your appliances.

France	Senlis	+33 (0)3 44 62 22 22
Germany	Nürnberg	+49 (0)911 323 2600
Italy	Pordenone	+39 (0)1678 47053
Sweden	Stockholm	+46 (0)20 78 77 50
UK	Newbury	+44 (0)1635 522 799

For the installer

1. Remove any promotion label from the door.
2. This oven can be used as a free standing oven or built-in, into a kitchen cabinet using kit number JMR260, which is supplied with the oven. To install the oven in a kitchen cabinet follow the instructions supplied with the building-in kit. The oven should be installed on a flat, level surface. The surface must be strong enough to safely bear the weight (18 kg) of the oven, and the contents. To avoid the possibility of causing vibration or noise the oven must be in a stable position.
3. Keep the oven away from heat and water. Exposure to heat and water can lower oven efficiency and lead to malfunctioning, so be sure to install the oven away from heat and water sources.
4. Do not block air vents on the top and the sides of the cabinet and also do not place any articles on the top of the oven. A gap all around the oven is necessary : 100 mm above the oven and any objects, 50 mm on the sides and behind the oven. If air vents are blocked during operation, the oven may overheat, and this may lead to malfunctioning. Hot air escapes from the vents, so be sure not to obstruct it or let curtains come between the oven and the rear wall.
5. Place the oven as far away from radios and TV's as possible. This oven does conform to EEC requirements* of radio interference suppression, but some interference may occur if it is placed too close to a radio or TV, so keep them as far apart as possible.
6. If positioned in a corner, leave a gap of at least 5 cm from the right side wall.

IMPORTANT! The oven can be placed almost anywhere in the kitchen. Make sure the oven is placed on a flat, level surface and that vents as well as the surface underneath the oven are not blocked (for sufficient ventilation).

Electrical connections



THIS APPLIANCE MUST BE EARTHED.
The manufacturer declines any liability should this safety measure not be observed.

If the plug that is fitted to your appliance is not suitable for your socket outlet, it must be cut off and the appropriate plug fitted.

Remove the fuse from the cut off plug. The cut off plug should then be disposed of to prevent the hazard of shocks in case it should be plugged into a 13 Amp socket in another part of your home.

IMPORTANT

The wires in the mains lead are coloured in accordance with the following code:

GREEN AND YELLOW	EARTH
BLUE	NEUTRAL
BROWN	LIVE

If you fit your own plug, the colours of the wires in the mains lead of your appliance may not correspond with the markings identifying the terminals in your plug, proceed as follows:

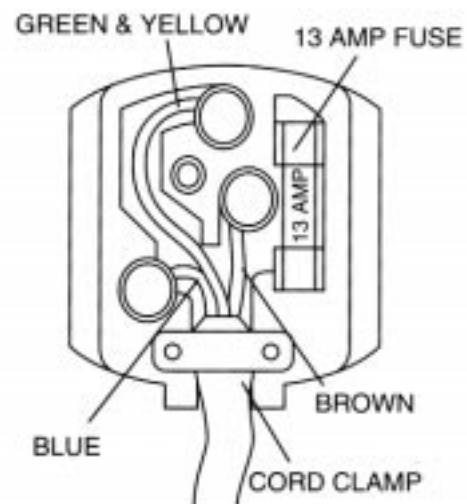

Connect the green and yellow (earth) wire to the terminal in the plug which is marked with the letter 'E' or the earth symbol (\equiv) or coloured green and yellow.

Connect the blue (neutral) wire to the terminal in the plug which is marked with the letter 'N' or coloured black.

Connect the brown (live) wire to the terminal in the plug which is marked with the letter 'L' or coloured red.

The plug moulded on to the lead incorporates a fuse. For replacement, use a 13 Amp BS1362 fuse. Only ASTA or BSI approved fuses should be used.

The plug must not be used if the fuse cover/carrier is lost. The cover/carrier is indicated by the coloured insert at the base of the plug.

A replacement cover/carrier is indicated by the coloured insert at the base of the plug.

A replacement cover/carrier must be obtained from your local Electrolux Service Centre.

This appliance complies with E.E.C. directive No. 87/308 of 2.6.87 relative to radio interference suppression.

Build-in model

To install the appliance in a kitchen cabinet, use the appropriate mounting frame. Note the relevant instructions for installation and connection. When building in to a high cabinet, you may use the lift-door. Note the relevant information for installation and connection given in the operating instructions of the lift door.

Attention !

Never operate the microwave oven with the lift door closed. Such operation would damage your appliance and invalidate the guarantee.

Technical data

Building in kit		JMR260	Power source	240 V, 50 Hz
Overall dimension	Width	495 mm	Fuse	13A
	Depth	384 mm	Power consumption	2550W
	Height	296 mm	Power Output	850W
Cavity	Width	315 mm	Grill	1300W
	Depth	315 mm	Weight	18 kg
	Height	205 mm		
Volume		18 l	MAFF Rating	D

Connecting to the mains

The oven is delivered with the power cord and a plug for 240 V, 50Hz, earthed socket outlet.

Earth protection minimizes the risks should a short-circuit occur. Check to ensure the voltage of the oven matches the supply.

N.B. If the oven is connected to the socket via an extension cord, make sure the cord is earthed.



This appliance must not be used on a non-earth protected power supply. Contact an electrician if you are uncertain regarding electrical connection of the oven or provision of earth protection of the supply. This appliance must be earthed. If this appliance is fitted with a non-rewirable plug for which your socket is unsuitable, the plug should be cut off and the appropriate plug fitted. If it is necessary to change the fuse in a nonrewirable plug, the fuse cover must be refitted. If the fuse cover is lost or damaged, the plug must not be used until a replacement is obtained.

Connect to a plug socket with protective earth contact and fused with a 16 A-L automatic device or 16 A slow-blowing fuse. When the oven is installed, there must be a possibility of disconnecting it from the mains with a contact break of at least 3 mm on all poles.

A suitable size of LS-switch, or a melting or fly-out fuse, are suitable contact-breakers.

Electrolux Service Force

CHANNEL ISLANDS

GUERNSEY Guernsey Electricity
PO Box 4
Vale, Guernsey
Channel Islands

JERSEY Jersey Electricity
Company
PO Box 45
Queens Road
St Helier
Jersey
Channel Islands
JE4 8NY

SCOTLAND

ABERDEEN8 Cornhill Arcade
(M05) Cornhill Drive
Aberdeen
AB2 5UT

AUCHTERMUCHY 33A Burnside
(M03) Auchtermuchy
Fife
KY14 7AJ

BLANTYRE Unit 5
(M07) Block 2
Auchenraith Industrial
Estate
Rosendale Way
Blantyre
G72 0NJ

DUMFRIES 93 Irish Street
(M01) Dumfries
Scotland
DG1 2PQ

DUNOON Briar Hill
(M 67) 7 Hill Street
Dunoon
Argyll
PA23 7AL

GLASGOW 20 Cunningham Road
(M04) Clyde Estate
Rutherglen,
Glasgow,
G73 1PP

INVERNESS Unit 3B
(M06) Smithton Indust. Est.
Smithton
Inverness
IV1 2PD

ISLE OF ARRAN Arran Domestic
Unit 4 The Douglas
Centre
Brodict
Isle of Arran
(OWN SALES) KA27 8AJ

ISLE OF BARRA J Zerfah
244 Bruernish
Isle of Barra
Western Islands
(OWN SALES) HS9 5QY

ISLE OF BUTE Walker Engineering
(M66) Glenmhor
Upper Serpentine Rd.
Rothsay
Isle of Bute
PA20 9EH

ISLE OF LEWIS ND Macleod
(M69) 16 James Street
Stornoway
Isle of Lewis
PA872QW

KELSO 2-8 Wood Market
(M08) Kelso
Borders TD5 7AX

ORKNEY Corsie Domestic
(M65)7 King Street
Kirkwall
Orkney KW15 1RE

SHETLAND Tait Electronic Systems Ltd.
Holmsgarth Road
Lerwick

(OWN SALES) Shetland ZE1 0PW
SHETLAND Bolts Shetland Ltd

26 North Road
Lerwick

(OWN SALES) Shetland ZE1 0PE

WHALSAY Leask Electrical
Harlsdale
Symbister, Whalsay
(OWN SALES) Shetland ZE2 9AA

NORTHERN IRELAND

BELFAST Owenmore House
(M27) Kilwee Industrial Estate
Upper Dunmury Lane
Belfast
BT17 0HD

WALES

CARDIFF Guardian Industrial
(M28) Estate
Clydesmuir Road
Tremorfa, Cardiff
CF2 2QS

CLYWD Unit 6-7 Coed - Parc
(M14) Abergele Road
Rhuddlan
Clwyd
Wales
LL18 5UG

OSWESTRY Plas Funnon Warehouse
(M17) Middleton Road
Oswestry
SY11 2PP

HAVERFORDWEST Cromlech Lodge
(M75) Amerlston
Haverfordwest
SA62 5DS

DYFED Maes Y Coen
(M11) High Mead
Llanybydder
Dyfed
SA40 9UL

NORTH EAST

GATESHEAD Unit 356a
(M39) Dukesway Court
Dukesway
Team Valley
Gateshead
NE11 0BH

GRIMSBY Unit 2
(M42) Cromwell Road
Grimsby
South Humberside
DN31 2BN

HULL Unit 1
(M41) Boulevard Industrial Estate
Hull
HU3 4AY

LEEDS 64-66 Cross Gates Road
(M37) Leeds
LS15 7NN

NEWTON AYCLIFFE Unit 16
(M45) Gurney Way
Aycliffe Ind Estate
Newton Aycliffe
DL5 6UJ

SHEFFIELD Pennine House
(M38) Roman Ridge Ind.
Roman Ridge Road
Sheffield
S9 1GB

NORTH WEST

BIRKENHEAD 1 Kelvin Park
(M11) Dock Road
Birkenhead
L41 1LT

CARLISLE Unit 8
(M10) South John Street
Carlisle
CA2 5AJ

ISLE OF MAN South Quay Ind Estate
(M64) Douglas
Isle of Man

LIVERPOOL Unit 1
(M15) Honeys Green Precinct
Honeys Green Lane
Liverpool
L12 9JH

MANCHESTER Unit 30
(M09) Oakhill Trading
Estate
Devonshire Road
Worsley
Manchester
M28 3PT

PRESTON Unit 250
(M13) Dawson Place
Walton Summit
Bamber Bridge
Preston
Lancashire
PR5 8AL

STOCKPORT Unit 20 Haigh Park
(M16) Haigh Avenue
Stockport
SK4 1QR

Electrolux Service Force

MIDLANDS

BIRMINGHAM 66 Birch Road East,
(M18) Wyrley Road Industrial
Estate
Witton
Birmingham
B67DB

BOURNE Manning Road Ind
(M44) Estate
Pinfold Road
Bourne
PE10 9HT

BRIDGNORTH 1 Underhill Street
(M72) Bridgnorth
Salop
WV16 4BB

GLOUCESTER 101 Rycroft Street
(M23) Gloucester
GL1 4NB

HEREFORD Unit 3
(M31) Bank Buildings
Cattle Market
Hereford
HE4 9HX

HIGHAM FERRERS 30 High Street
(M51) Higham Ferrers
Northants
NN10 8BB

ILKESTON Unit 2
(M43) Furnace Road
Ilkeston
DE7 5EP

LEICESTER Unit 7
(M22) Oaks Industrial Estate
Coventry Road
Narborough
Leicestershire
LE0 5GF

LINCOLN Unit 8 Stonefield Park
(M40) Clifton Street
Lincoln
LN5 8AA

NEWCASTLE 18-21 Croft Road
UNDER LYME Brampton Industrial
(M12) Estate
Newcastle under Lyme
Staffordshire
ST5 0TW

NUNEATON 19 Ptarmigan Place
(M21) Townsend Drive
Nuneaton
CV11 6RX

REDDITCH 13 Thornhill Road
(M20) North Moons Moat
Redditch
Worcestershire
B98 0NH

TAMWORTH Unit 3
(M19) Sterling Park
Claymore
Tamworth
B77 5DO

WORCESTER Unit 1
(M73) Northbrook Close
Gregorys Mill Ind Estate
Worcester
WR3 8BP

LONDON & EAST ANGLIA

CANVEY ISLAND 2-4 Sandhurst

Kings Road
Canvey Island
SS8 0QY

CHELMSFORD Hanbury Road
(M47) Widford Ind Estate
Chelmsford
Essex
CM12 3AE

COLINDALE Unit 14
(M53) Capital Park
Capital Way
Colindale
London NW9 0EQ

ENFIELD 284 Alma Road
(M49) Enfield
London
EN3 7BB

GRAVESEND Unit B4,
(M57) Imperial Business Estate
Gravesend
Kent
DA11 0DL

HARPENDEN Unit 4
(M46) Riverside Estate
Coldharbour Lane
Harpenden
AL5 4UN

LETCHWORTH 16-17 Woodside Ind Est.
(M50) Works Road
Letchworth
Herts
SG6 1LA

LETCHWORTH 16-17 Woodside Ind Est.
(M50) Works Road
Letchworth
Herts
SG6 1LA

LONDON 2/4 Royal Lane
(M76) Yiewsley
West Drayton
Middlesex
UB7 8DL

MOLESEY 10 Island Farm Avenue
(M61) West Molesey
Surrey
KT8 2UZ

NEWBURY PO BOX 5672
(M24) Newbury
Berkshire
RG14 5GF

IPSWICH Unit 2B
(M48) Elton Park Business Centre
Hadleigh Road
Ipswich
IP2 0DD

NORWICH 2b Trafalgar Street
(M52) Norwich
NR1 3HN

SUNBURY Unit 1a
(M63) The Summit
Hanworth Road
Hanworth Ind Estate
Sunbury on Thames
TW16 5D

SYDENHAM Unit 6
(M62) Metro Centre
Kangley Bridge Road
Sydenham
SE26

SOUTH EAST

ASHFORD Unit 2
(M58) Bridge Road Business
Estate
Bridge Road
Ashford
Kent
TN2 1BB

FLEET Unit 1
(M59) Redfields Industrial
Estate
Church Crookham
Fleet
Hampshire
GU13 0RD

HAYWARDS HEATH 21-25 Bridge Road
(M55) Haywards Heath
Sussex
RH16 1UA

TONBRIDGE Unit 30 Deacon
Trading (M56) Estate
Morley Road
Tonbridge
Kent
TN9 1RA

SOUTH WEST

BARNSTAPLE P.O. Box 12
(M30) Barnstaple
North Devon
EX31 2YB

BOURNEMOUTH 63-65 Curzon Road
(M26) Bournemouth
Dorset
BH1 4PW

BRIDGEWATER 6 Hamp Industrial Estate
(M35) Bridgewater
Somerset

BRISTOL 11 Eldon Way
(M25) Eldonwall Trading
Bristol
Avon
BS4 3QQ

EMSWORTH 266 Main Road
(M33) Southboure
Emsworth
PO10 8JL

ISLE OF WIGHT Unit 8
(M34) Enterprise Court
Ryde Business Park
Ryde
Isle of Wight
PO33 1DB

NEWTON ABBOT Unit 2
(M29) Zealley Industrial Estate
Kingsteignton
Newton Abbot
S. Devon
TQ12 3TD

PLYMOUTH 16 Faraday Mill
(M32) Cattledown
Plymouth
PL4 0ST

REDRUTH Unit 7D Pool Industrial
(M36) Estate
Wilson Way, Redruth,
Cornwall
TR15 3QW



This file has been downloaded from:

www.UsersManualGuide.com

User Manual and User Guide for many equipments like mobile phones, photo cameras, mother board, monitors, software, tv, dvd, and othes..

Manual users, user manuals, user guide manual, owners manual, instruction manual, manual owner, manual owner's, manual guide, manual operation, operating manual, user's manual, operating instructions, manual operators, manual operator, manual product, documentation manual, user maintenance, brochure, user reference, pdf manual