

ZANUSSI

BUILT-IN ELECTRIC

DOUBLE OVEN

AND GRILL

ZHF865

INSTRUCTION BOOKLET

IMPORTANT SAFETY INFORMATION

These warnings are provided in the interests of your safety. Ensure that you understand them all before installing or using the cooker. Your safety is of paramount importance. If you are unsure about any of the meanings of these warnings contact the Customer Care Department. The address is on the back page of this book.

INSTALLATION

- The cooker must be installed according to the instructions supplied. The installation work must be undertaken by a qualified electrician/ competent person.
- The cooker must be installed in an adequately ventilated room.
- NOTE: It is imperative that the appliance is left in the base to protect both the appliance and the floor.
- This cooker is heavy and care must be taken when moving it. **Do not** try to move the cooker by pulling the door handles.
- Warning: **Do Not** attempt to lift this appliance by the handles.
- All packaging, both inside and outside the cooker must be removed before the cooker is used.
- It is dangerous to alter the specifications or modify the cooker in any way.
- After installation please dispose of the packaging with due regard for safety and the environment. Your local authority can arrange this.

CHILD SAFETY

- **Do not** allow young children to play with any part of the packaging.
- This cooker is designed to be operated by adults. Young children must not be allowed to tamper with the controls or play near or with the cooker.
- During use the cooker becomes hot, care should be taken to avoid touching heating elements inside the oven.
- The cooker and accessible parts especially around the grill area become hot when the cooker is in use. Keep children away until it has cooled.

DURING USE

- This cooker has been designed for domestic use to cook edible foodstuffs only, and must not be used for any other purpose.
- Take great care when heating fats and oils as they will ignite if they become too hot.
- Never place plastic or any other material which may melt in or on the oven.
- **Do not** stand too close to the oven or grill while in use as warm air will exhaust from the grill cavity and the vents on the front frame of the cooker.
- **Do not** leave the grill pan handle in position when grilling and ensure oven gloves are used to remove and replace the handle, as it will become hot.
- Always use oven gloves to remove and place food in the oven.

- Never line any part of the cooker with aluminium foil.
- Stand clear when opening the drop down oven doors. Support the doors using the handles until fully open.
- **Never leave the cooker unattended when the oven door is open.**
- **Do not** place sealed cans or aerosols inside the oven. They may explode if they are heated.
- Ensure that all control knobs are in the OFF position when not in use.
- **Do not** stand on the cooker or on the open oven doors.
- **Do not** hang towels, dishcloths or clothes from the cooker or its handles. They are a safety hazard.

CLEANING AND MAINTENANCE

- The cooker is heavy and care must be taken when moving it.
- **For Hygiene and safety reasons this cooker should be kept clean at all times. A build-up of fats or other foodstuffs could result in a fire especially in the grill pan.**
- **Do not** leave cookware containing foodstuffs, e.g. fat or oil in the cooker in case it is inadvertently switched on.
- Always allow the cooling fan to cool the cooker down before switching off at the wall prior to carrying out any cleaning / maintenance work.
- Only clean this cooker in accordance with the instructions given in this book.

SERVICE

- Repairs should not be carried out by inexperienced persons as this may cause injury or serious malfunction. This cooker should be serviced by an authorised Service Engineer and only genuine approved spare parts should be used. Details of servicing and repair arrangements are supplied on page 38 of this book.

AT THE END OF THE COOKERS LIFE

- When the time comes to dispose of your cooker please contact your local Council Authority. They can arrange to dispose of the cooker in a safe and controlled manner.
- The number will be in the telephone book.



Please read this instruction book carefully before use and retain for future reference.

CONTENTS

FOR THE USER

Important Safety Information	2
Description of the cooker	4
Getting to Know Your Oven	5
The Cooling Fan for the Controls	6
Control Panel Indicator Neons	6
Before Using The Cooker	7
Rating Plate	7
When First Switching On	7
Condensation and Steam	7
Cookware	8
The Trivet	8
Grill and Oven Furniture	9
The Electronic Timer	10
The Dual Grill	13
Uses of the Grill	13
How To Use the Dual Grill	13
Things To Note	13
The Grill Pan and Handle	14
Hints and Tips	14
Grilling Chart	16
The Top Oven	17
Uses of the Top Oven	17
How To Use the Top Oven	17
Things To Note	17
To Fit the Top Oven Shelf	17
Hints and Tips	18
Top Oven Cooking Chart	19
The Fan Oven	20
Uses of the Fan Oven	20
How To Use the Fan Oven	20
Things to Note	20
To Fit the Fan Oven Shelves	21
Hints and Tips	21
Fan Oven Cooking Chart	22
Roasting Chart	23
Defrost Feature	24
Uses of Defrost Feature	24
How To Defrost	24
Things to Note	24
Hints and Tips	24

Care and Cleaning

Cleaning Materials	26
Cleaning the Outside of the Cooker	26
Cleaning the Outer and Inner Door	
Glass Panels	27
Cleaning the Fan Oven	28
Cleaning the Grill / Top Oven Compartment	29
To Clean the Top Oven Roof	29
To Remove the Wirework Runners	29
Cleaning the Shelves, Wirework Runners and Oven Furniture	30
Care Of Stayclean Surfaces	30
The Oven Cleaning Cycle	30
Hints and Tips	30
Cooking To Reduce Soilage	31
Replacing an Oven Light Bulb	32
If Something Doesn't Work	33
Guarantee Conditions	35
Service and Spare Parts	36

FOR THE INSTALLER

Technical Details	39
Things You Need to Know	40
Warnings	40
Choice of Electrical Connection	40
Things to Note	41
Preparing Cabinet for Fitting Oven	42
How to Finish Unpacking	43
Making the Electrical Connections	44
To Remove Cover of Mains Terminal	44
Connecting to the Mains Terminal	45
Checking Electrical Connections	46
Connecting to a Hob or Cooker Point	46
Fitting into the space between cabinets	47
Notes	48
Rating Plate Reference	Back cover

Please read the whole instruction book before using the cooker. To help you the following symbols will be found in the text.



Safety Instructions



Step by Step Instructions



Hints and Tips

DESCRIPTION OF THE COOKER

Built in electric double oven



WARNING: THIS COOKER MUST BE EARTHED

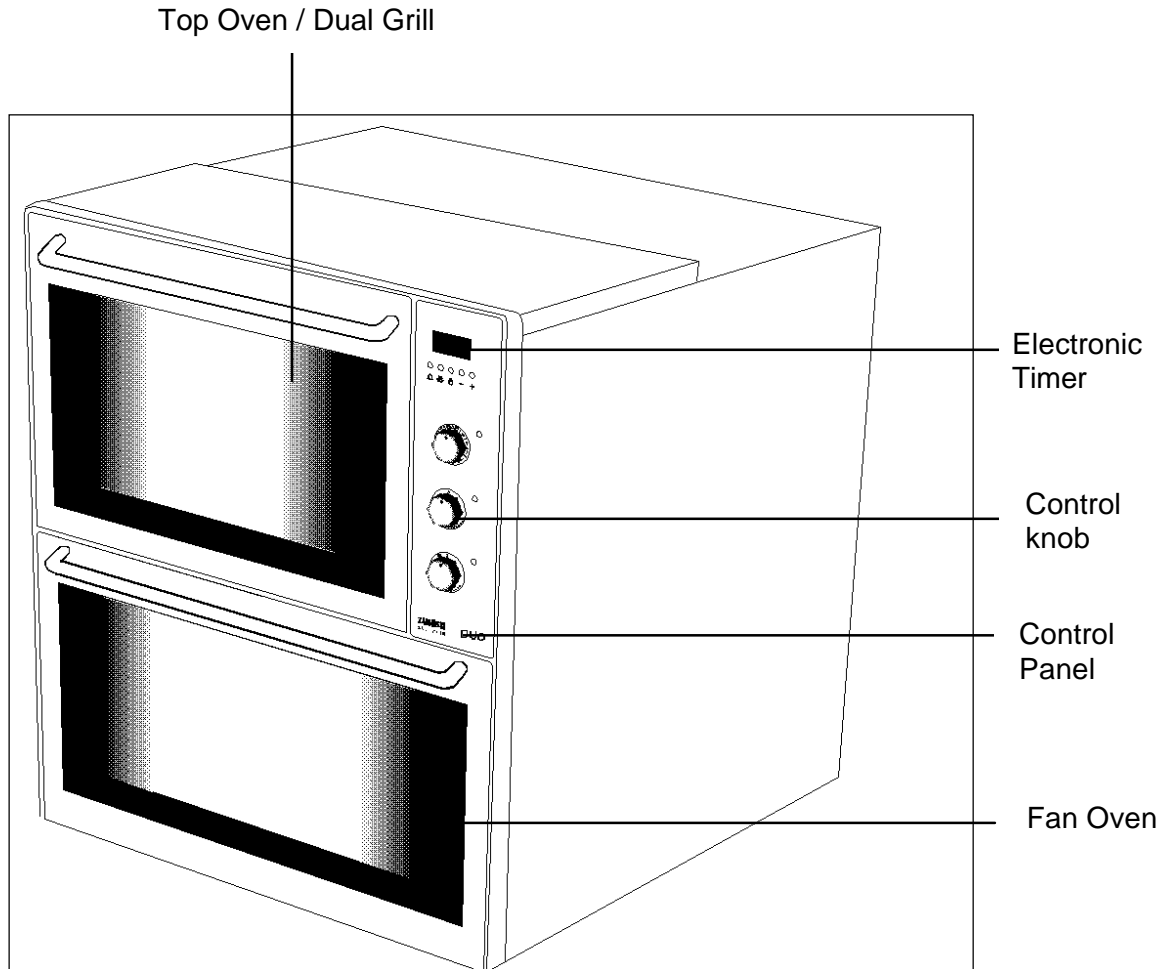

Your built in cooker comprises of a conventional oven and dual grill in the top compartment. The top oven is convenient and economical for mid week use because of its size.

The fan oven is the larger of the two ovens. It is particularly suitable for cooking larger quantities of food.

The fan oven can be automatically controlled by the electronic timer.

GETTING TO KNOW YOUR OVEN

The Control Panel

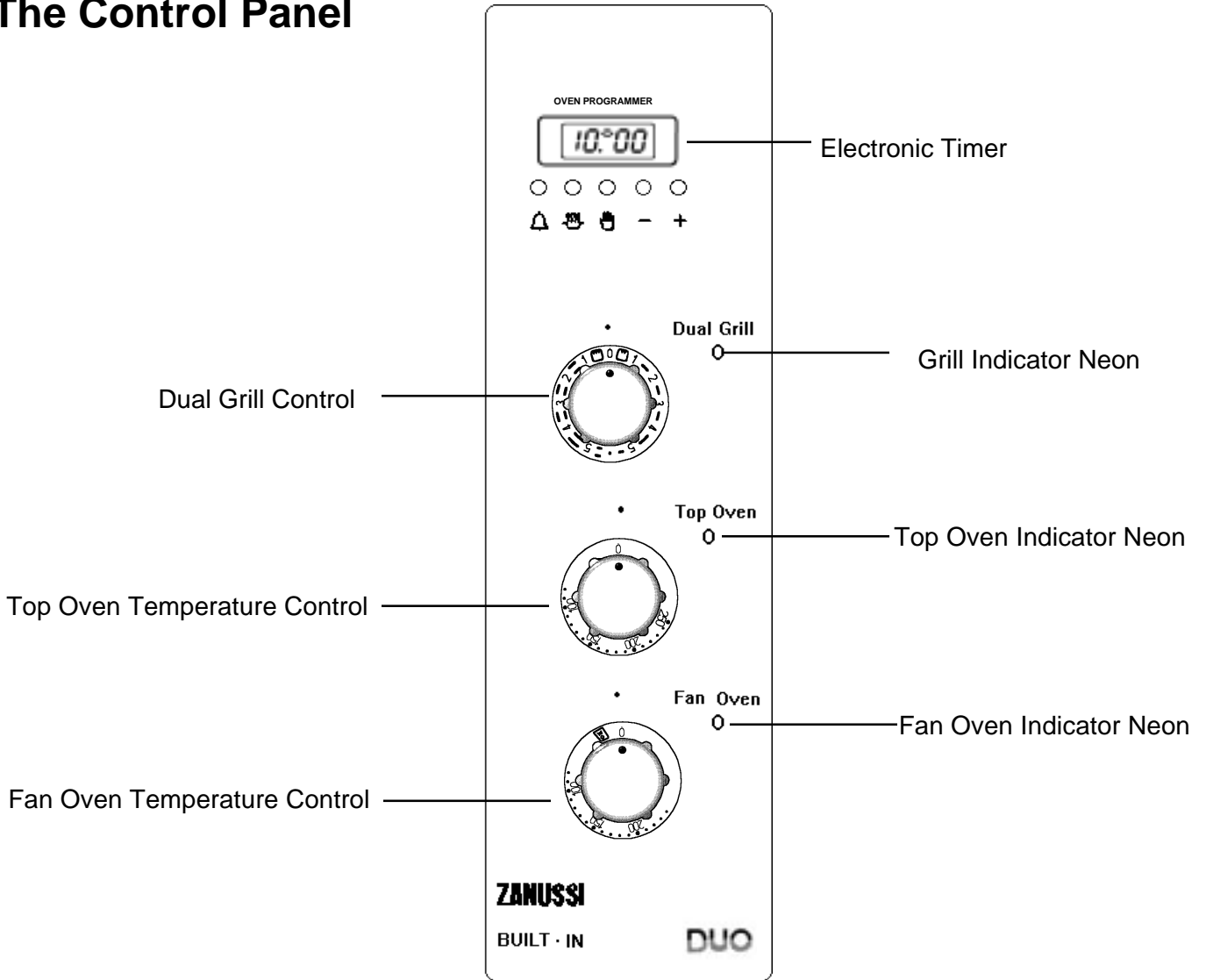

THE COOLING FAN FOR THE CONTROLS

Your cooker has a cooling fan fitted behind the controls to prevent them from overheating. The cooling fan will come on immediately when the grill is switched on and after a short time when either of the ovens are in use. The cooling fan may turn on and off when the cooker is in use. This is quite normal.

The cooling fan may run on after the ovens or grill are switched off for a period of time to cool the cooker down. It may continue to switch on and off until the cooker is cool.



Always allow the cooling fan to cool the cooker down before switching off at the wall prior to carrying out any cleaning or maintenance work.

NOTE

The action of the cooling fan will depend on how long the ovens or grill have been used and at what temperature. It may not switch in at all at lower temperature settings nor run on where the grill or oven has only been used for a short time.

CONTROL PANEL INDICATOR NEONS

These lights indicate whether the ovens or grill are switched on. When the grill or ovens are switched on the neon illuminates. In the case of the ovens, the neons also indicate when the set temperature has been reached. They will turn on and off during use to show that the temperature is being maintained.

The grill neon does not turn on and off when the grill is in use.

The fan oven neon does not operate with the Defrost function.

If the neons do not operate as the instructions indicate the controls have been incorrectly set. Return all controls to zero and re-set following the instructions for the required setting.

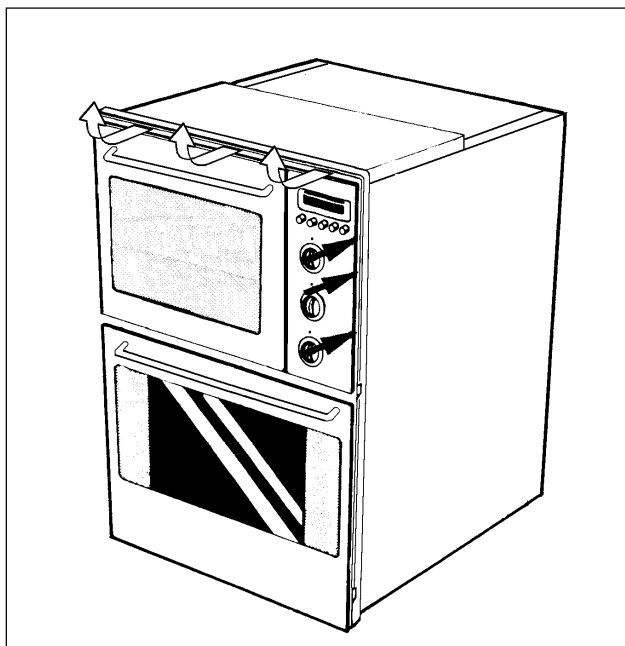

BEFORE USING THE COOKER

RATING PLATE

Record the model, product and serial numbers of your cooker on the back page of this instruction book for future reference. You can find these numbers on the rating plate on the front frame of the cooker upon opening the top oven door.

The cooker must be protected by a suitably rated fuse or circuit breaker. The rating of the cooker is given on the rating plate.

Do not remove the rating plate from the cooker as this may invalidate the guarantee.

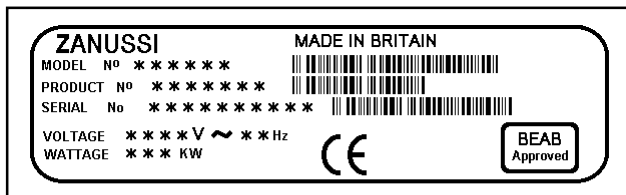

PREPARING TO USE YOUR COOKER

Wipe over the base of the ovens with a soft cloth and hot soapy water and wash the grill and oven furniture before use.

We suggest that you run the oven elements for 10 - 15 minutes at 220°C to burn off any residue from their surfaces.

The procedure should be repeated with the grill for approximately 5 - 10 minutes.

During this period an odour may be emitted, it is therefore advisable to open a window for ventilation.

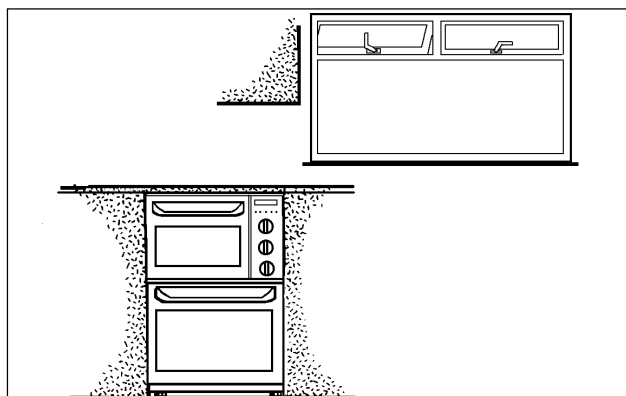

WHEN FIRST SWITCHING ON

The timer must be set to manual operation before the Fan oven can be operated. This must be done whenever the cooker is switched off at the wall or when there has been a power failure. For instructions on how to set the timer see page 10.

If the Fan oven indicator neon does not glow when the oven temperature control is turned, it is most likely that the timer is set for automatic cooking.

The Top Oven and the Dual Grill are not controlled by the electronic timer.

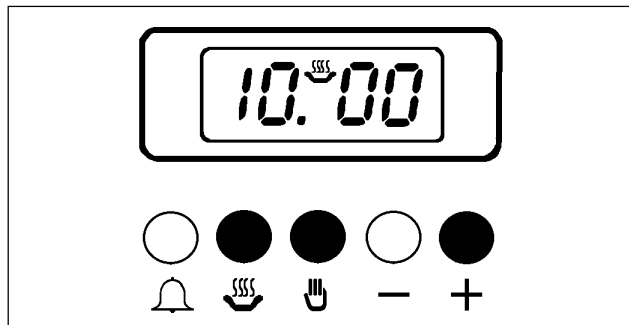

CONDENSATION AND STEAM

When food is heated it produces steam in the same way as a boiling kettle does. The ovens are vented to allow some of this steam to escape. However, always stand back from the cooker when opening the oven doors to allow any build up of steam or heat to release. If the steam comes into contact with a cool surface on the outside of the cooker, e.g. a trim, it will condense and produce water droplets. This is quite normal and is not caused by a fault on the cooker.

To prevent discolouration occurring, regularly wipe away condensation and any soilage from the cooker surfaces.

COOKWARE

Baking trays, dishes etc., should not be placed directly against the grid covering the fan at the back of the oven.

Do not use baking trays larger than 30cm x 35cm (12" x 14") as they will restrict the circulation of heat and may affect performance. Advice on the effect of different materials and finishes of bakeware is given in 'Hints and Tips' in the appropriate oven section.

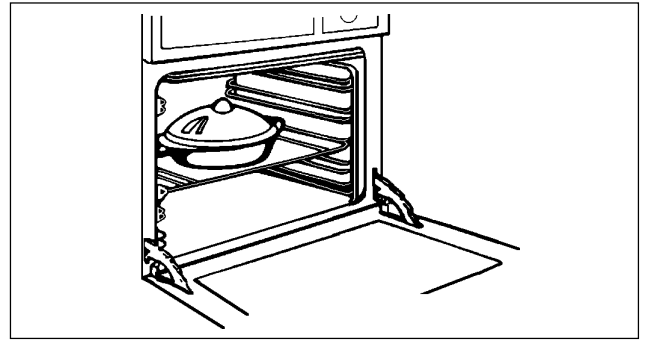

THE TRIVET

When roasting we recommend that you use the trivet in the meat tin. Fat and meat juices will drain into the meat tin below and can be used to make gravy. The trivet also prevents splashes of fat from soiling the oven interior.

Note. The meat tin should not be placed on a heated hotplate as this may cause the enamel to crack.

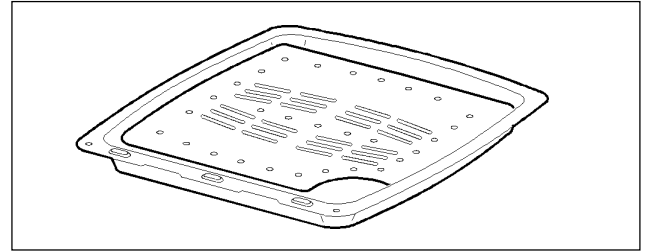

GRILL AND OVEN FURNITURE

The following items of oven furniture have been supplied with the cooker.

1 grill pan

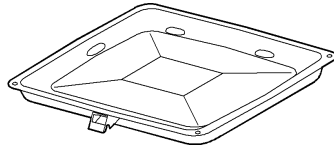

1 grill pan handle

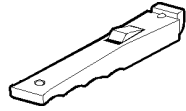

1 grill pan grid

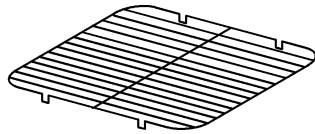

1 trivet

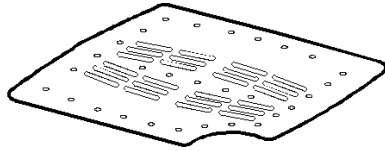

1 meat tin

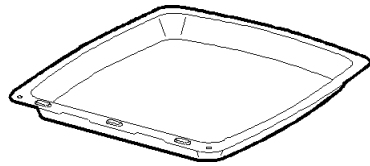

2 shelves for fan oven cooking

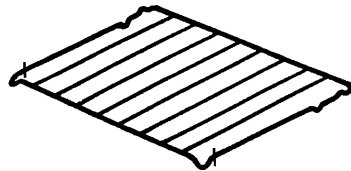

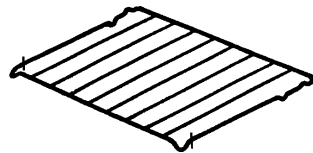

1 shelf for grilling and top oven cooking



THE ELECTRONIC TIMER

The electronic timer can indicate the time of day, operate as a minute minder and automatically time the Fan oven.



- A Auto Symbol (automatic cooking)
-  Bell Symbol (minute minder)
-  Cookpot Symbol (manual cooking)

Please note that this is a 24 hour clock, for example 2pm is shown as 14.00.

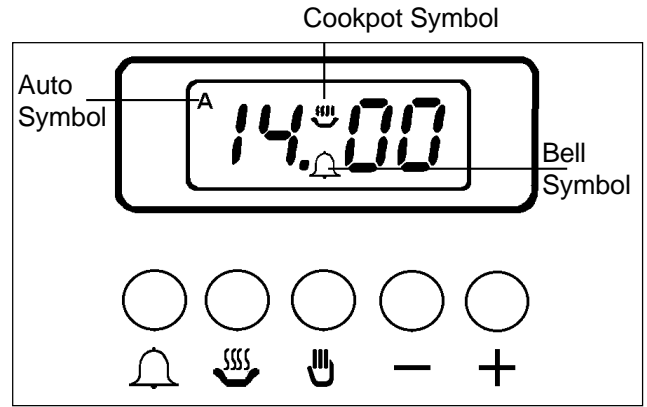
If the oven is switched off at the wall or there is loss of power the clock will stop and you will not be able to use the cooker. When you first switch the electricity supply on, the timer display will flash.



TO SET THE TIME OF DAY

1. Press buttons  and  together. Release the buttons.
2. Within 5 seconds press the + button until the time of day shows in the display.

The cookpot symbol () will be showing.

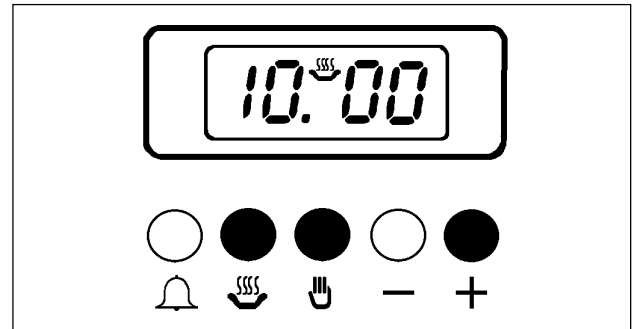

THE MINUTE MINDER

1. Press and release the  button.
2. Within 5 seconds press the + button until the display shows the time you want.

Our diagram shows the timer set to 5 minutes. After a few seconds the time of day will show in the display.

When you are using the minute minder you can check the number of minutes remaining by pressing the  button.

At the end of the timed period an alarm will sound. Switch off the alarm by pressing the  button.

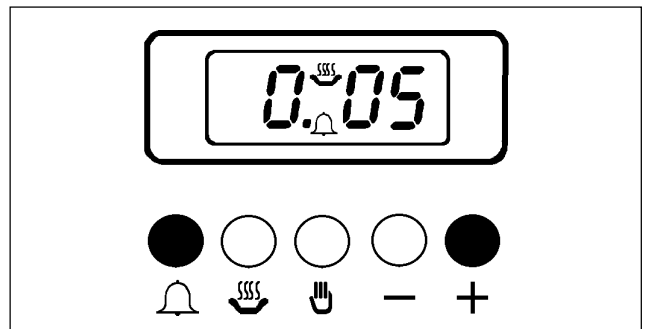

After a few seconds the time of day shows in the display.



AUTOMATIC TIMER CONTROL

The automatic timer can be used with the Fan oven only.

TO SWITCH THE FAN OVEN ON AND OFF AUTOMATICALLY

1. Ensure the clock is showing the correct time of day.
2. Place food in the fan oven.
3. Set the length of time you want the food to cook for by pressing and releasing the  button and then pressing the + button until the correct cooking time is displayed.
This must be completed within 5 seconds of pressing the  button.

The maximum cooking time is 23 hours 59 minutes.

The Cookpot and Auto symbols will show in the display. Our diagram shows the cooking time set for 2 hours 30 minutes.

After a few seconds the time of day shows in the display.

4. To set the time you want the food to be cooked by, press and release the  button. This will show you the earliest possible stop time.

If this is different to the time you want the food to be cooked by, press the + button within 5 seconds until the correct stop time shows in the display. Our diagram shows the food is to be cooked by 18.00 hours (6pm).

After a few seconds the time of day shows in the display and the Cookpot symbol goes out. The 'Stop' time must not be more than 23 hours 59 minutes from the time of day. For example, if the time of day is 09.00 hours (9.00am) the latest 'Stop' time will be 08.59 (8.59am) the next day.

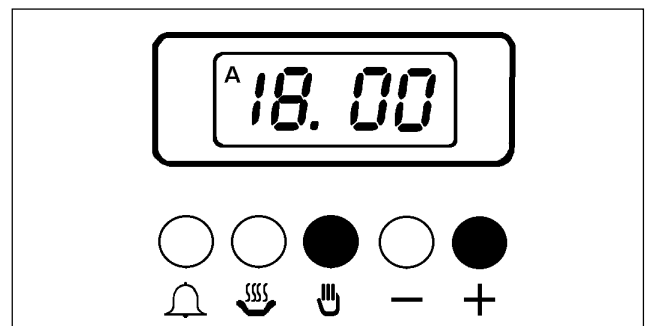
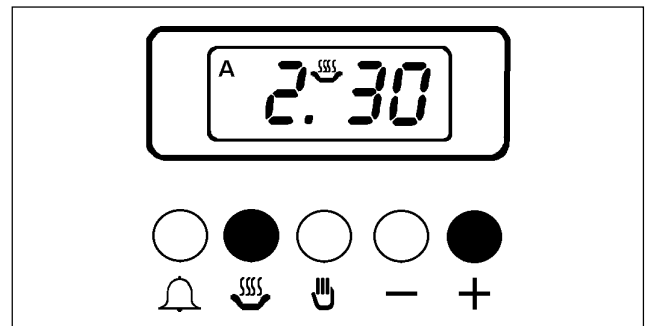

5. Turn the oven control to the correct temperature.

The clock will work out what time the oven will switch itself on and will switch the oven off at the end. An audible signal will sound when cooking is complete. To cancel the alarm, see below.



RETURNING THE COOKER TO MANUAL OR TO CANCEL AN AUTOMATIC PROGRAMME

Once automatic cooking is complete an alarm will sound and the Auto symbol will flash to remind you that the oven needs to be set for manual operation.

1. To do this press buttons  and  together. After a few seconds the timer will show the time of day. The cookpot will show in the display and the oven will switch on again.

2. Turn the oven control off.

TO SET THE TIMER TO SWITCH OFF ONLY

This is useful if you want to begin cooking immediately but have the Fan oven switch off whilst you are out.

1. Ensure the clock is showing the correct time of day.
2. Place food in the oven.
3. Set the length of time you want the food to cook for. Press and release the  button and then within 5 seconds press the + button until the correct cook time is showing.



Our diagram shows the timer set for 2 hours 30 minutes.

After a few seconds the time of day shows in the display.

4. Turn the oven temperature control to the required setting. The oven indicator neon will come on.

If you want to check the time the oven will switch off simply press the  button and the 'Stop' time will be displayed.

At the end of the cooktime the oven will switch off, the alarm will sound and the auto symbol will flash.

5. To cancel and return to manual operation press buttons  and  together.

6. Turn off the oven temperature control.

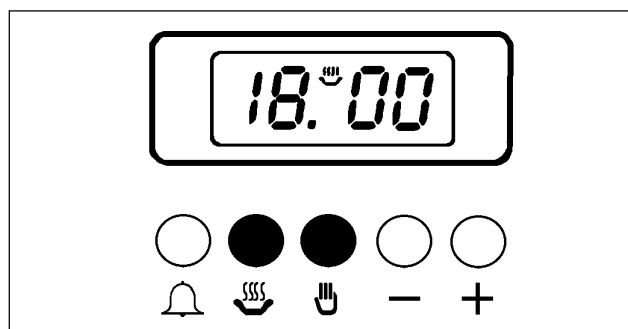
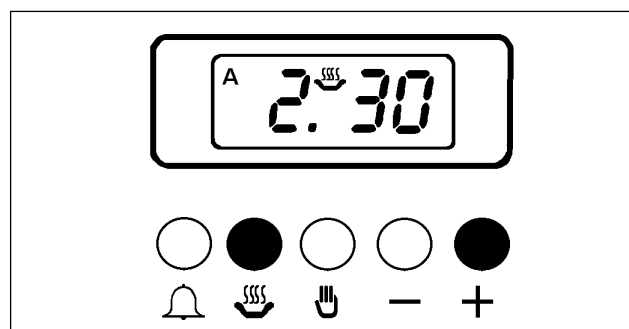
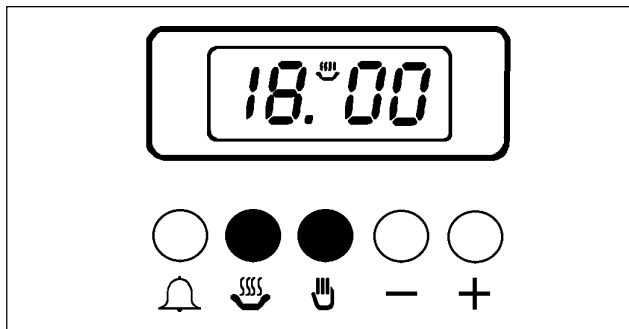

THE DUAL GRILL

 **WARNING** - Accessible parts become hot when the grill is in use. Keep children away.

USES OF THE GRILL

The grill is situated in the Top oven compartment.

The grill is a dual circuit grill which means that the full area of the grill or the centre section only can be used. Use the full grill for cooking larger quantities of food. Use the centre section for economy purposes when cooking smaller quantities of food.

HOW TO USE THE DUAL GRILL

1. Open the Grill / Top Oven door.
2. Turn the grill control clockwise for full grill or anticlockwise for the centre section only.
3. Ensure the Top Oven control is in the Off position '0'.

 **The grill door must be left open when grilling.**

THINGS TO NOTE

- The cooling fan for the controls will operate as soon as the grill control is turned. For more information on the operation of the cooling fan turn to page 6.
- The inner section of the grill element may appear to glow brighter than the outer section. This is quite normal.
- The grill indicator neon will glow until the desired power level has been reached. It will turn ON and OFF periodically during cooking showing that the temperature is being maintained.
- We recommend you use the grill pan on the shelf in positions 3 or 5 only.
- If you use the grill pan in position 3 the shelf must be withdrawn before the pan can be located or removed.

 **Ensure the grill pan is properly located.**

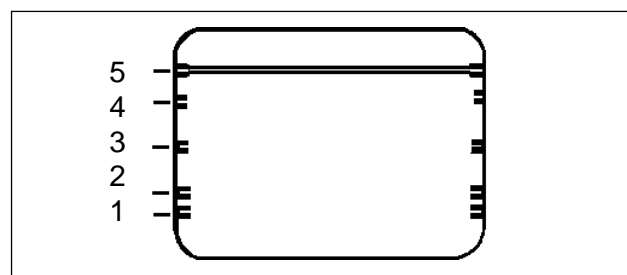
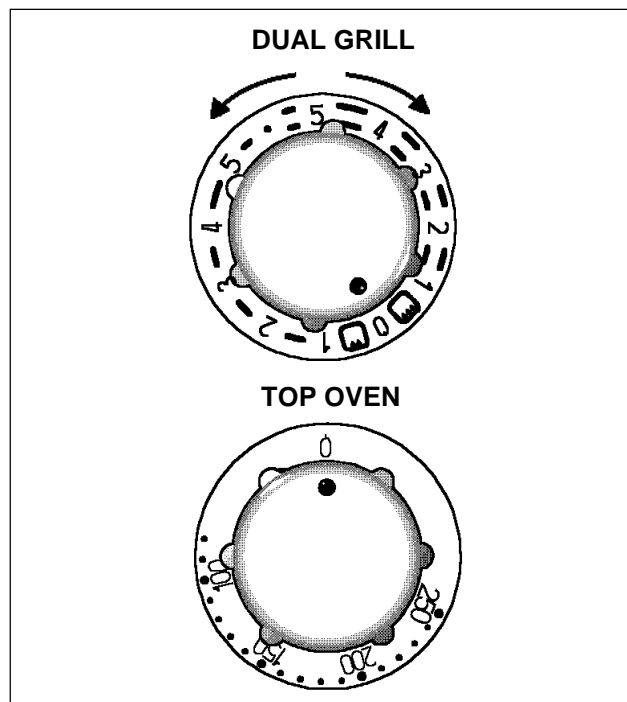

THE GRILL PAN AND HANDLE

The grill pan has a removable handle.

To insert the handle, press the button on the handle with the thumb and pivot the handle slightly upwards inserting the lip into widest part of the bracket. Move the handle towards the left, lower into position and release the button.

 **Ensure the handle is positively located.**

To remove the handle, press the button on the handle with the thumb and pivot the handle slightly upwards and towards the right to remove from the bracket.

 **Protect your hands when removing the grill pan handle.**

Always remove the grill pan handle during grilling.

To correctly locate the grill pan on the shelf, ensure that the cut out on the underside of the handle bracket locates over the front bar of the shelf.

 **The Grill Pan must not be located in the shelf runners.**

To check the progress of the food being grilled, the grill pan should be withdrawn on the shelf to attend to food during cooking.

 **Ensure that you support the grill pan when it is withdrawn.**

HINTS AND TIPS

- Most foods should be placed on the grilling grid in the grill pan. This allows maximum circulation of air by raising the food out of fats and juices.
- Adjust the grid and grill pan runner position to allow for different thicknesses of food. Position the food close to the element for faster cooking and further away for more gentle cooking.

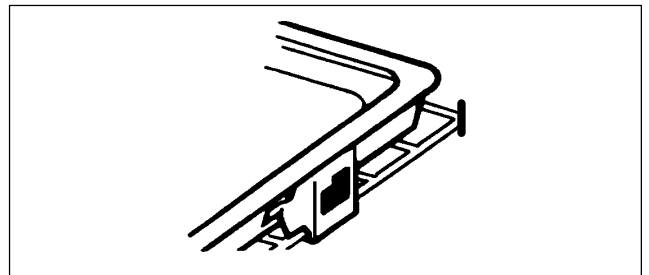
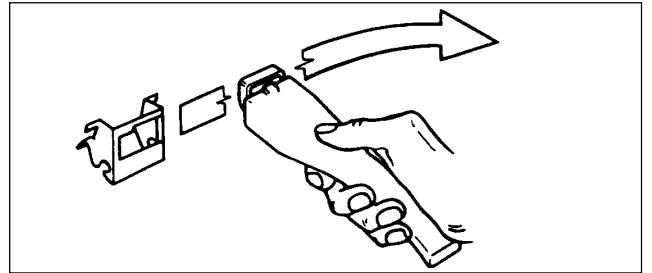
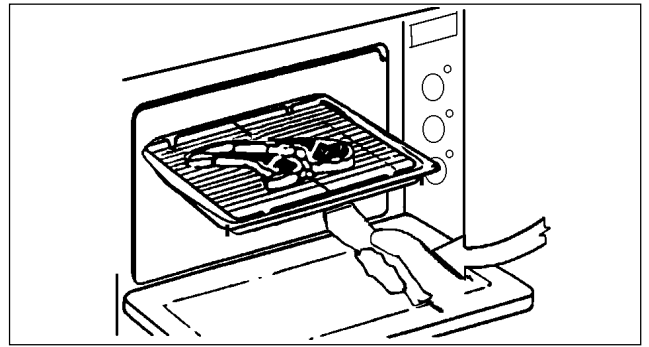

- The grill pan grid is reversible. This is useful if you want to cook foods of varying thickness. As a general rule, bread for toasting should be placed on the grid in the ' high ' position in the grill pan. Foods such as chicken pieces or chops may be grilled using the grilling grid in the low position.



- Food should be thoroughly dried before grilling to minimise splashing. Brush lean meats and fish lightly with a little oil or melted butter to keep them moist during cooking.



- Accompaniments such as tomatoes and mushrooms may be placed underneath the grid when grilling meats.

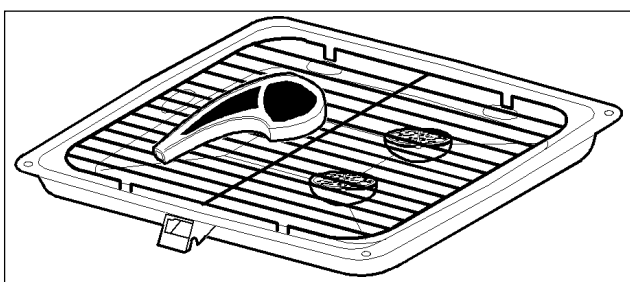

- The food should be turned over during cooking as required.

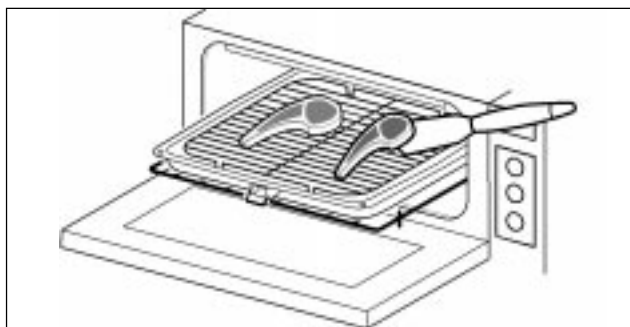

- The grill door must be left open when grilling. For convenience the grill door can be left ajar.



- Preheat the grill on full setting for a few minutes before searing steaks or toasting. Adjust the heat setting and the shelf position as necessary during cooking.

GRILLING CHART

The chart below gives recommended cooking times and shelf positions. Remember that these are a guide and should be adjusted to suit personal taste.

Note

Shelf positions are counted from the bottom upwards.

FOOD	Grill Time (Min)	Shelf	Grid Position
Bacon Rashers	3 - 5 each side	5	High
Beefburgers	6 - 10 each side	5	Low
Chicken Joints	15 - 20 each side	3	High
Chops - Lamb	7 - 10 each side	5	Low
- Pork	10 - 15 each side	5	Low
Fish - Whole Trout / Herring	8 - 12 each side	5	Low
Fillets - Plaice / Cod	4 - 6 each side	5	Low
Kebabs	10 - 15 each side	5	Low
Kidneys - Lamb	4 - 6 each side	5	Low
Pig	8 - 10 each side	5	Low
Liver - Lamb / Pig	5 - 10 each side	5	Low
Sausages	10 - 15 turn as required	5	Low
Steaks - Rare	3 - 6 each side	5	Low
Medium	6 - 8 each side	5	Low
Well Done	7 - 10 each side	5	Low
Browning e.g. au gratin, lasagne, shepherd's pie	3 - 5 mins	3	-

THE TOP OVEN

USES OF THE TOP OVEN

The top oven is the smaller of the two ovens. The top oven gives you the option of cooking without the fan. It is convenient for mid-week meals where smaller quantities or convenience foods are being cooked. It is important to refer to the top oven cooking chart as a guide to shelf positions and temperatures as these may differ from previous cookers you may have used.

The top oven is also ideal for use as warming compartment to warm dishes and keep food hot. Use a temperature setting of 80°C - 100°C on the top oven temperature control.

HOW TO USE THE TOP OVEN

1. Turn the Top Oven temperature control to the required setting.

THINGS TO NOTE

- The top oven indicator neon will glow until the oven has reached the desired temperature and then go out. It will turn on and off periodically during cooking showing that the temperature is being maintained.
- The cooling fan for the controls may operate after a time. See page 6 for more information on the operation of the cooling fan.



Do not place dishes, tins and trays directly on the oven base as it becomes very hot and damage will occur.

TO FIT THE TOP OVEN SHELF

There are 5 shelf positions in the top oven. Shelf positions are counted from the bottom upwards.

The shelf should be fitted with the straight rods uppermost on the frame and the forms towards the back of the oven.

If not fitted correctly the anti-tilt and safety stop mechanism will be affected.

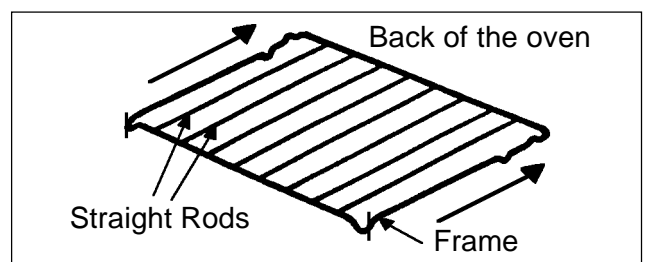
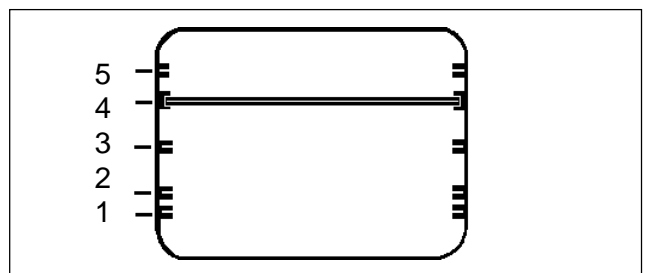
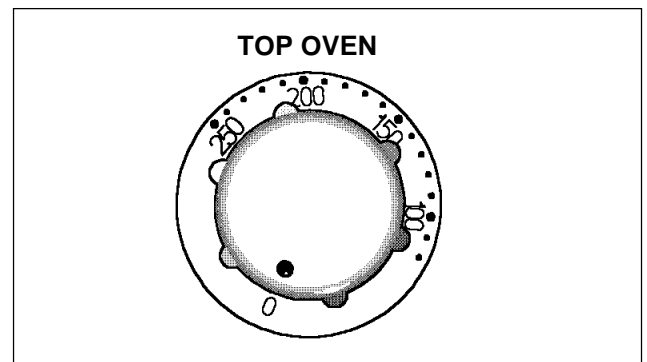

i HINTS AND TIPS

- Use the top oven when you want to warm plates. Use a setting of 80°C - 100°C on the oven temperature control.
- You can only cook on one shelf when using the top oven. For the best results food should be placed in the centre of the oven. To increase top browning e.g. for au gratin dishes, the food should be placed towards the top of the oven. Similarly for foods which benefit from the base being browned, e.g. pizza, quiches and flans place the food on a lower shelf.
- There should always be at least 2.5cm (1") between the top of the food and the grill element. This gives best cooking results and allows room for rise in yeast mixtures, Yorkshire puddings etc. When cooking cakes, pastry, scones bread etc., place the tins or baking trays centrally on the shelf.
- Ensure that food is placed centrally on the shelf and there is sufficient room around the baking tray or dish to allow for maximum circulation.
- Where a larger quantity of food is to be cooked we recommend you use the main fan oven.
- Place dishes on a suitably sized baking tray on the shelf to prevent spillage onto the oven base and to help reduce cleaning.
- The material and finish of the baking tray and dishes will affect the degree of base browning of the food. Enamelware, dark, heavy or non-stick utensils increase base browning. Shiny aluminium or polished steel trays reflect the heat away and give less base browning.
- **Do not** use the grill pan or meat tin as a baking tray as this will increase base browning of the food.
- Because of the smaller cooking space and lower temperatures, shorter cooking times are sometimes required. Be guided by the recommendations in the cooking chart.
- For economy leave the door open for the shortest possible time, particularly when placing food into a pre-heated oven.

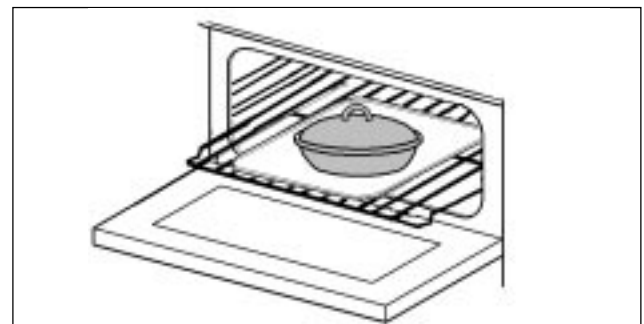
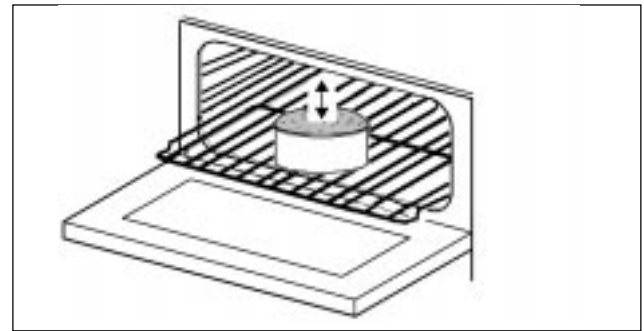
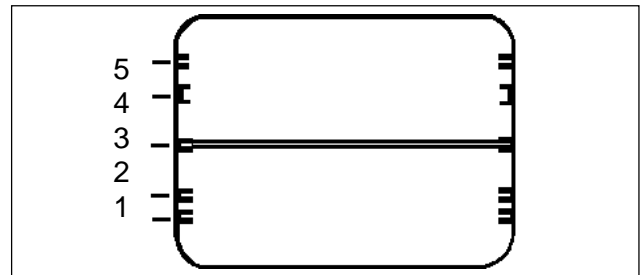

TOP OVEN COOKING CHART

Note: Shelf positions are counted from the bottom of the oven.

FOOD	SHELF POSITION	TEMP (°C)
Biscuits	3	170 -190
Bread	3	210 - 220
Bread Rolls / Buns	3	210 -220
Cakes: Small & Queen	3	180 - 190
Sponges	2	180 - 190
Victoria Sandwich	2	180 - 190
Madeira	3	160 - 170
Rich Fruit	3	140 - 150
Gingerbread	3	150 - 160
Meringues	2	80 - 100
Flapjack	3	180 - 190
Shortbread	3	140 - 150
Baked Custard	3	160 - 170
Casseroles : Beef / Lamb	2	150 - 160
Chicken	2	140 - 160
Convenience Foods	3	According to manufacturers instructions
Fish	3	170 - 190
Fish Pie - potato topped	3	200 - 210
Fruit Pies, Crumbles	3	190 - 200
Milk Puddings	3	140 - 150
Pasta / Lasagne etc.	3	190 - 200
Pastry : Choux - eclairs/profiteroles	3	190 - 200
Flaky / Puff pies	3	200 -210
Shortcrust	3	190 - 200
Mince pies	3	190 - 200
Meat pies	3	210 - 220
Quiche, Tarts, Flans	3	180 - 190
Roast Meat / Poultry	1	160 - 180
Scones	3	220 -230
Shepherds Pie	3	200 - 210
Soufflés	3	190 - 200
Vegetables : Baked Jacket Potatoes	3	190 - 200
Roast Potatoes	3	200 - 210
Yorkshire Puddings - large	3	210 - 220
- individual	3	210 - 220

THE FAN OVEN

USES OF THE FAN OVEN

The fan oven is particularly suitable for cooking larger quantities of food.

The advantages of fan oven cooking are:

PREHEATING

The fan oven quickly reaches its temperature so it not usually necessary to preheat the oven. Without preheating however you may need to add an extra 5 - 10 minutes on the recommended cooking times. For recipes needing high temperatures e.g. bread, pastries, scones, soufflés etc., best results are achieved if the oven is preheated first.

COOKING TEMPERATURES

Fan oven cooking generally requires lower temperatures than conventional cooking. Follow the temperatures recommended in the chart on page 22 until you are familiar with the lower temperatures associated with Fan oven cooking. As a guide reduce temperatures by 20°C - 25°C for your own recipes.

BATCH BAKING

The fan oven cooks evenly on all shelf levels, especially useful when batch baking.

HOW TO USE THE FAN OVEN

1. Turn the oven temperature control to the required setting.

THINGS TO NOTE

- The oven light will come on when the control is turned.
- The oven fan will operate continually during cooking.
- The cooling fan for the controls may operate after a time. See page 6 for further details on the operation of the cooling fan.
- The fan oven indicator neon will glow until the oven has reached the desired temperature. It will turn on and off periodically during cooking showing that the temperature is being maintained.
- If an automatic programme has been set, the oven fan and oven light do not come on until the cook time begins.

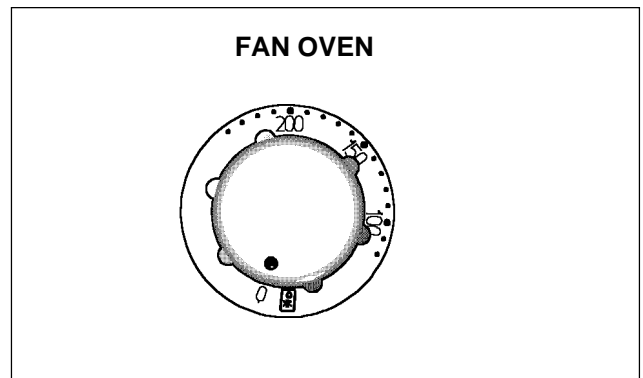
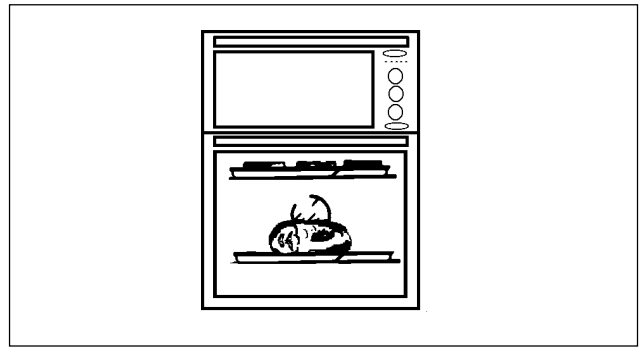

TO FIT THE FAN OVEN SHELVES

The shelves should be fitted with the straight rods uppermost on the frame and the forms towards the back of the oven. If not fitted correctly the anti-tilt and safety stop mechanism will be affected.

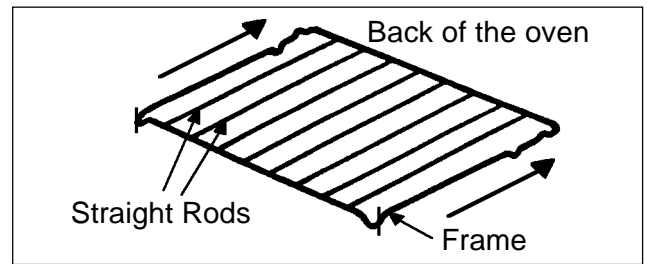

i HINTS AND TIPS

- Arrange the shelves in the required positions before switching the oven on. Shelves are numbered from the bottom upwards.
- When cooking more than one dish in the fan oven, place dishes centrally on different shelves rather than cluster several dishes on one shelf, this will allow the heat to circulate freely for the best cooking results.
- It is recommended that when baking larger quantities, the shelf positions should be evenly spaced to suit the load being cooked. A slight increase in cooking time may be necessary.
- The use of excessively high temperatures can cause uneven browning. It may be necessary to reduce temperatures slightly. Refer to the recommendations given in the oven cooking chart, on page 22.
- The material and finish of the baking tray and dishes will affect the degree of base browning of the food. Enamelware, dark, heavy or non-stick utensils increase base browning. Shiny aluminium or polished steel trays reflect the heat away and give less base browning.

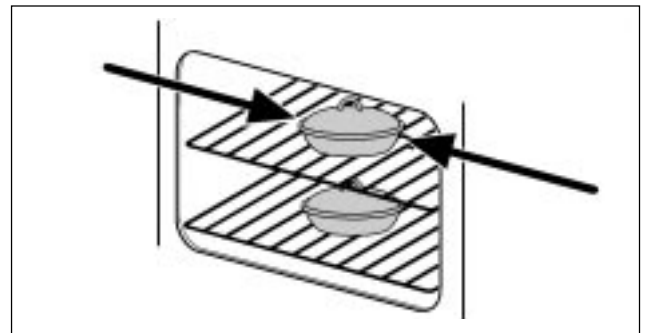
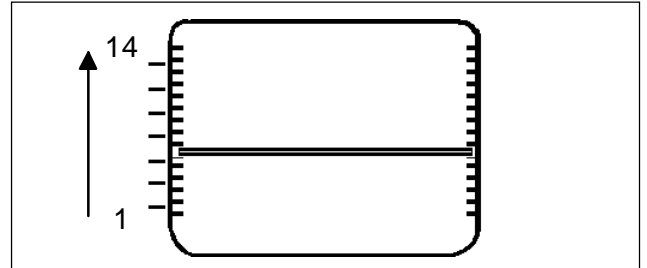

FAN OVEN COOKING CHART

The oven temperatures are intended as a guide only. It may be necessary to increase or decrease the temperatures by a further 10°C to suit individual preferences and requirements.

Note: Shelf positions are counted from the bottom of the oven.

FOOD	SHELF POSITION	TEMP (°C)
Biscuits	2 & 12	160 -190
Bread	1 & 9	210 -220
Bread Rolls / Buns	2 & 12	210 -220
Cakes:		
Small & Queen	2 & 12	160 -170
Sponges	4 & 11	160 -170
Victoria Sandwich	4 & 11	160 -170
Madeira	7	140 - 150
Rich Fruit	7	140 -150
Christmas	7	130 - 140
Gingerbread	4 & 11	140 -150
Meringues	4 & 11	90 - 100
Flapjack	4 & 11	170 - 180
Shortbread	7	140 - 150
Baked Custard	7	140 - 150
Casseroles :		
Beef / Lamb	7	140 - 150
Chicken	7	160 -180
Convenience Foods	Any	According to Manufacturers Instructions
Fish	7	150 - 170
Fish Pie - potato topped	7	190 - 200
Fruit Pies, Crumbles	4 & 11	180 -190
Milk Puddings	7	130 - 140
Pasta / Lasagne etc.	7	180 - 190
Pastry : Choux -		
Eclairs/profiteroles	4 & 11	160 - 170
Flaky / Puff pies	7	210 - 220
Shortcrust -		
Mince pies	4 & 11	170 - 180
Meat pies	4 & 11	210 - 220
Quiche, Tarts, Flans	7	180 - 190
Roast Meat / Poultry	4	160 - 180
Scones	2 & 12	200 -210
Shepherds Pie	7	190 - 200
Soufflés	7	170 - 180
Vegetables :		
Baked Jacket Potatoes	7	190 - 200
Roast Potatoes	7	200 - 210
Yorkshire Puddings - large	10	210 -220
- individual	10	210 -220

ROASTING CHART

ROASTING CHART		
INTERNAL TEMPERATURES Rare: 50 - 60°C; Medium: 60 - 70°C; Well Done: 70 - 80°C		
MEAT	FAN OVEN	COOKING TIME
Beef	160 - 180°C	20 - 35 min per ½kg/1lb and 20 - 35 min over
Beef, boned	160 - 180°C	20 - 35 min per ½kg/1lb and 25 - 35 min over
Mutton and Lamb	160 - 180°C	25 - 35 min per ½kg/1lb and 25 - 35 min over
Pork and Veal	160 - 180°C	30 - 40 min per ½kg/1lb and 30 - 40 min over
Ham	160 - 180°C	30 - 40 min per ½kg/1lb and 30 - 40 min over
Chicken	160 - 180°C	15 - 20 min per ½kg/1lb and 20 min over
Turkey and Goose	160 - 180°C	15 - 20 min per ½kg/1lb up to 3½kg/7lb then 10 min per ½kg/1lb over 3½kg/7lb
Duck	160 - 180°C	25 - 35 min per ½kg/1lb and 25 - 30 min over
Pheasant	160 - 180°C	35 - 40 min per ½kg/1lb and 35 - 40 min over
Rabbit	160 - 180°C	20 min per ½kg/1lb and 20 min over
Potatoes with meat	160 - 180°C	according to size
Potatoes without meat	180 - 190°C	according to size

The roasting temperatures and times given in the chart should be adequate for most joints, but slight adjustments may be required to allow for personal requirements and the shape and texture of the meat. However, lower temperatures and longer cooking times are recommended for less tender cuts or larger joints.

Wrap joints in foil if preferred, for extra browning uncover for the last 30 - 60 min. cooking time.

DEFROST FEATURE

USES OF DEFROST FEATURE

This fan oven function enables you to defrost most foods without heat faster than some conventional methods as the oven fan circulates air around the food. It is particularly suitable for delicate frozen foods which are to be served cold e.g. cream filled gateaux, cakes covered with icings or frostings, cheesecakes, biscuits, scones etc.

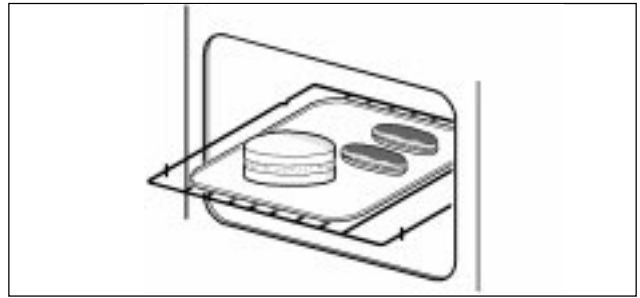

HOW TO DEFROST

1. Turn the Fan Oven temperature control to Defrost setting. 
2. This function **DOES NOT** require a temperature setting on the fan oven temperature control.

FAN OVEN

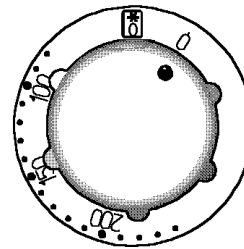

THINGS TO NOTE

- The oven fan and internal oven light will operate.



HINTS AND TIPS

- Place the frozen food in a single layer where possible and turn it over half way through the defrosting process.
- The actual speed of defrosting is influenced by room temperature. On warm days defrosting will be faster than on cooler days.
- It is preferable to thaw fish, meat and poultry slowly in the fridge. However, this process can be accelerated by using the defrost function. Small or thin fish fillets, frozen peeled prawns, cubed or minced meat, liver, thin chops, steaks etc., can be thawed in 1 - 2 hours.
- A 1kg/2¼lb oven ready chicken will be thawed in approximately 5 hours. Remove the giblets as soon as possible during the thawing process.

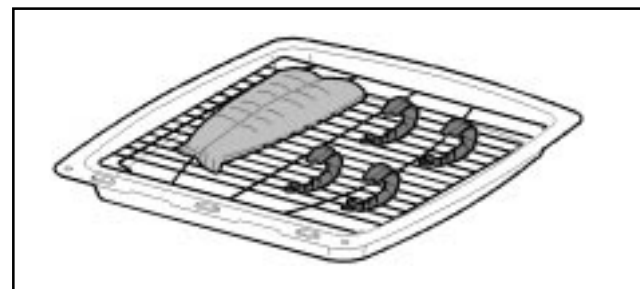
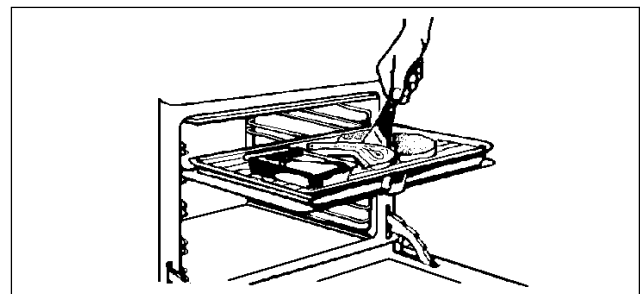

- Joints of meat up to 2kg/4½lb in weight can be thawed using the defrost function.
- All joints of meat and poultry must be thawed thoroughly before cooking.
- Always cook thoroughly immediately after thawing.
- **DO NOT** leave food at room temperature once it is defrosted. Cook raw food immediately or store cooked food in the fridge, once it has cooled.
- Care must always be taken when handling foods in the home. Always follow the basic rules of food hygiene to prevent bacterial growth and cross contamination when defrosting, preparing, cooking cooling and freezing foods.

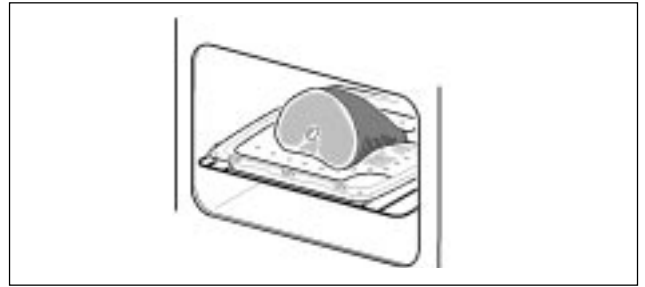

CARE AND CLEANING



Before cleaning the cooker always allow the cooling fan for the controls to cool the cooker down before switching off the electricity supply.

CLEANING MATERIALS

Before using any cleaning materials on your cooker, check that they are suitable and that their use is recommended by the manufacturer.

Cleaners that contain bleach should NOT be used as they may dull the surface finishes. Harsh abrasives should also be avoided.



CLEANING THE OUTSIDE OF THE COOKER

DO NOT use abrasive cleaning materials or scourers on the outside of the cooker as some of the finishes are painted and damage may occur. Regularly wipe over the control panel and oven doors using a soft cloth well wrung out in warm water to which a little liquid detergent has been added.

To prevent streaking on stainless steel models finish with a soft cloth. **Any spillage on the stainless steel finish must be wiped off immediately.**

Stainless Steel cream cleaners are abrasive and should be avoided as they may dull the surface finish.

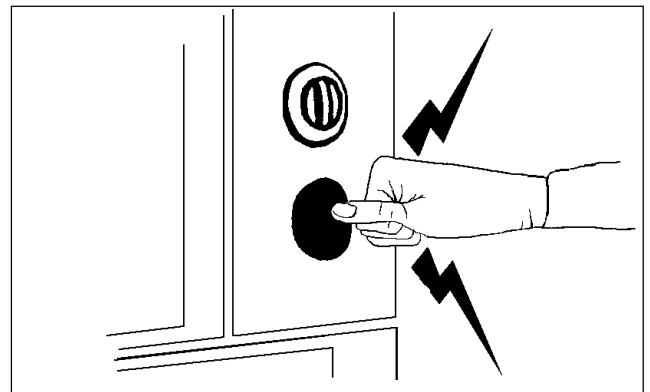
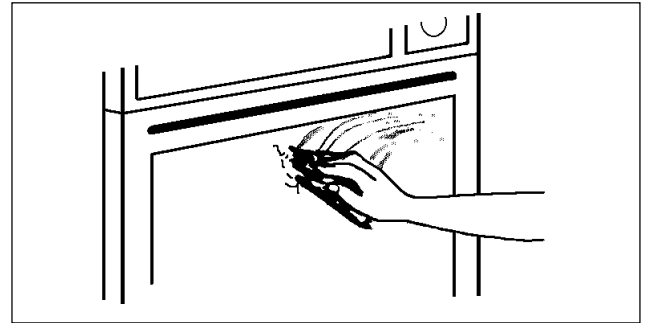

Do not attempt to remove any of the control knobs from the panel as this may cause damage and is a safety hazard.

CLEANING THE OUTER AND INNER DOOR GLASS PANELS



To prevent damaging or weakening the door glass panels avoid the use of the following:

- Household detergents and bleaches
 - Impregnated pads unsuitable for non-stick saucepans
 - Brillo/Ajax pads or steel wool pads
 - Chemical oven pads or aerosols
 - Rust removers
-

The outer oven door glass panels are removable for cleaning.

TO REMOVE THE OUTER GLASS

1. Open the oven door slightly to gain access to the two cross head screws on the top of the oven door.
2. Loosen the two screws using a Pozidrive screwdriver.
3. Holding the door glass securely in place with one hand remove the screws and washers with the other hand.
The screws and washers retain the trim on the top of the grill door. Note the position of the trim on the door.
4. Holding the door and glass with one hand, pull towards you and slightly lift the door glass with the other hand to disengage the panel from the location point at the bottom of the door. Gently release the door to close it.
5. Clean the outer and inner glass using hot soapy water or Hob Brite. Should the inner face of the outer door glass be heavily soiled it is recommended that soapy water with a high concentration of soap is used. To prevent streaking a glass cleaning spray may be applied and the glass polished with a soft cloth. Ensure that all parts are well rinsed and thoroughly dry before attempting to replace the outer door glass.

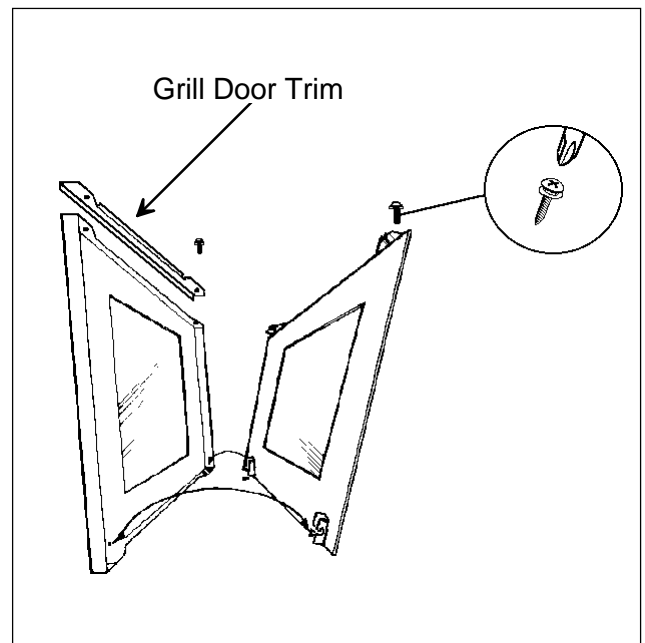

If the door glass panel becomes chipped or has deep scratches the glass will be weakened and must be replaced to prevent the possibility of the panel shattering. Please contact your local Service Force Centre who will be pleased to advise further.

TO REPLACE THE OUTER DOOR GLASS

1. Holding the door glass panel with both hands, gently place the locators into the holes of the brackets at the bottom of the oven door.
2. Holding the door glass with your left hand, use your right hand to open the oven door. Bring the door gently towards the glass panel ensuring the screw location holes line up.
3. Place the trim in the correct position on the top of the grill door.
4. Hold the glass in place with one hand and insert the cross head screws with washers into the location holes with the other hand. Give the screws one turn to ensure the glass is secure.
5. Tighten the screws positively with a Pozidrive screwdriver before closing the oven door.

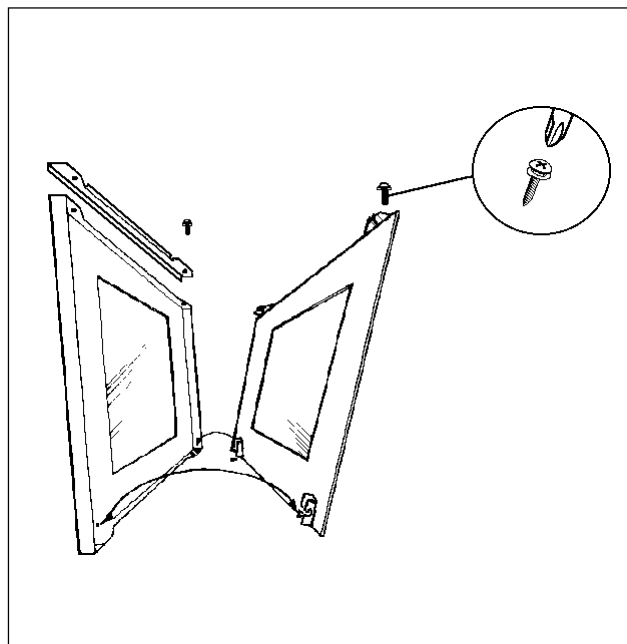

 **DO NOT attempt to use the oven without the glass being in place.**

TO CLEAN THE INNER GLASS DOOR

The inner glass door is not removable. Clean using hot soapy water or Hob Brite and a soft cloth. **DO NOT** use abrasives as they may damage the glass or seal.

CLEANING THE FAN OVEN

The fan oven top, sides and back panel are coated with a Stayclean finish.

The Stayclean areas in the fan oven should not be cleaned manually. See Care of Stayclean Surfaces on page 30.

The fan oven base can be cleaned using normal oven cleaners or aerosol oven cleaners with care. Ensure that the manufacturers instructions are followed and that all parts are well rinsed afterwards.

Do not use any cleaning agents or scrapers on the oven sides, back panels and door seal.

Damage will occur if soap impregnated steel wool pads, aerosol cleaners or any abrasive cleaners are used.

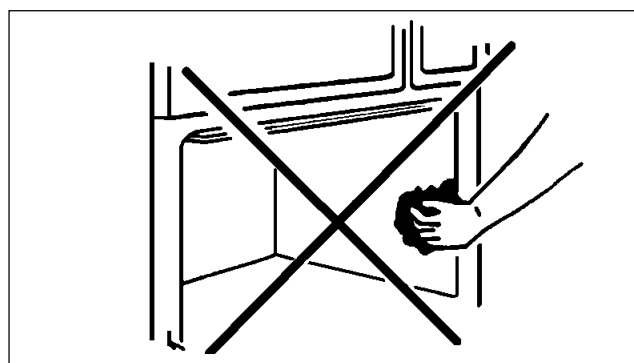

CLEANING THE GRILL / TOP OVEN COMPARTMENT

The grill / top oven compartment base, sides and back panel can be cleaned using oven cleaners or aerosol oven cleaners with care. Ensure that the manufacturers instructions are followed and that all parts are well rinsed afterwards. Aerosol cleaners must not come into contact with the grill element as this may cause damage.

TO CLEAN THE TOP OVEN ROOF

The grill element is hinged to make cleaning the oven roof easier.



Switch off the cooker from the electricity supply before cleaning and ensure the oven is cold.

1. Remove the wirework side runners. See below.
2. Undo the screw which holds the grill element in place.
3. Gently pull the element downwards to allow access to the oven roof. **Do not** force the element downwards.
4. Clean the top of the oven with Cif cream cleaner and a sponge scourer. If heavily soiled, aerosol oven cleaners may be used following the instructions given above for cleaning the grill / top oven compartment.
5. Gently push the grill element back into place.
6. Fit the screw to hold the element in place and tighten firmly.
7. Replace the wirework side runners.



Ensure the screw is firmly in place after cleaning.

TO REMOVE THE WIREWORK RUNNERS

The wirework runners in both ovens can be removed for cleaning.

1. Remove all shelves and furniture from the oven.
2. Hold the wirework at the bottom and gently pull towards the centre of the oven.
3. Unhook the runner at the top and remove it from the cavity.
4. To replace, hook the wirework back into the oven sides.



Ensure that the wirework runners are firmly in place before refitting the oven shelves.

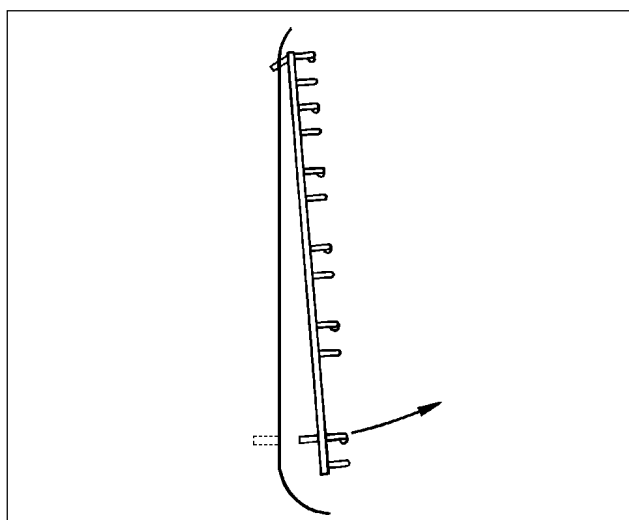
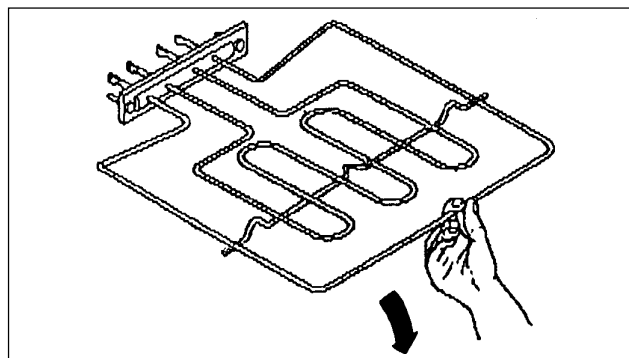
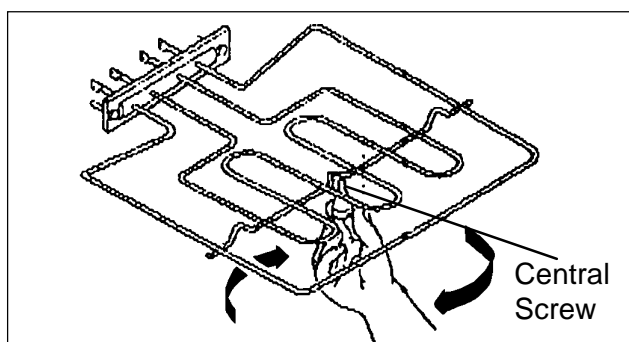
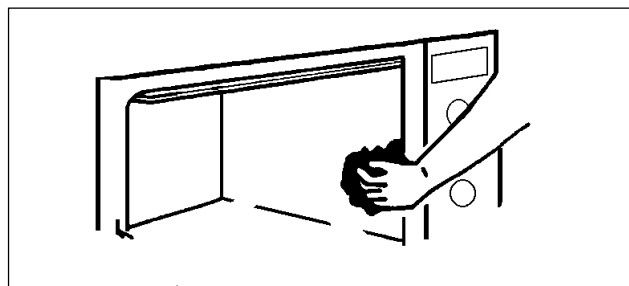

CLEANING THE SHELVES, WIREWORK RUNNERS AND OVEN FURNITURE

Soak the oven shelves, wirework runners and grilling grid in hot soapy water if heavily soiled, they will then clean more easily. If the shelves are heavily soiled a soap impregnated steel wool pad can be used.

The grill pan, meat tin and trivet can be cleaned using a soap impregnated steel wool pad.

All items of grill and oven furniture are dishwasher safe with the exception of the grill pan handle.

CARE OF STAYCLEAN SURFACES

The fan oven top, sides and back panel are coated with a special Stayclean coating. They should not be cleaned manually.

Aerosol cleaners must not be used on Stayclean surfaces and must not come into contact with elements or the door seal as this may cause damage.

During normal use the Stayclean coating will become splashed with fats and food residues. By running the oven without food, the Stayclean surfaces burn off any soilage. Regular use of the Oven cleaning cycle will help to keep the panels in good condition.

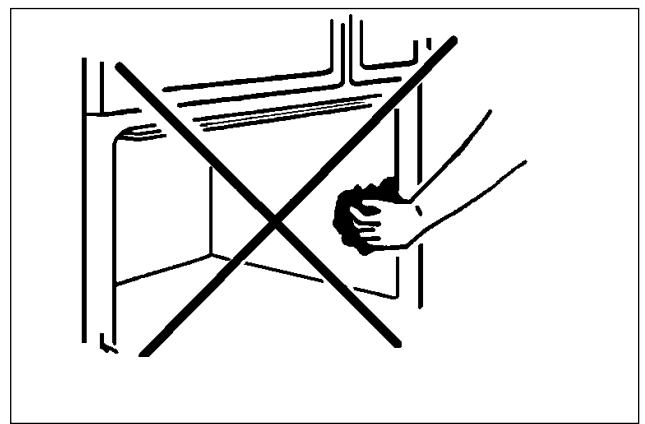

THE OVEN CLEANING CYCLE - FAN OVEN ONLY

1. Remove oven shelves, wirework runners and bakeware from oven.
2. Turn the fan oven temperature control to 220°C and allow the oven to run for an hour or so.

HINTS AND TIPS

- Slight discolouration and polishing of the Stayclean surfaces may occur in time, but this will not affect their self cleaning properties.
- A good time to use the oven clean function is after the weekly roast.
If you do a lot of roasting and very little baking you should follow the cleaning cycle every week. If you roast very little you will only need to follow the cleaning cycle every 2 - 3 weeks.
- Follow the recommendations on the next page to keep soilage to a minimum.

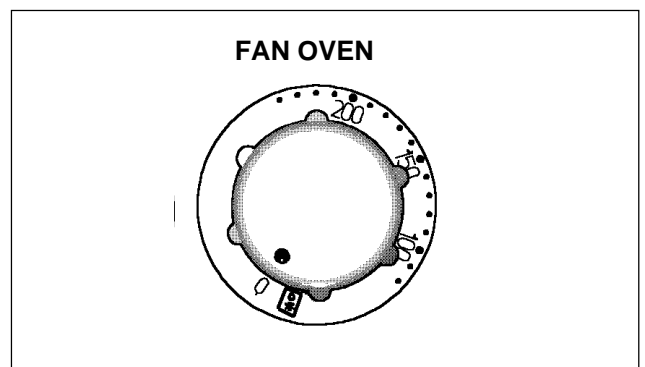

COOKING TO REDUCE SOILAGE

- Cook at the recommended temperatures. Higher temperatures during roasting will increase soilage. Try cooking at lower temperatures for an increased length of time, you will save energy and often the joint is more tender.
- Use minimal, if any, extra oil or fat when roasting meat, potatoes only require brushing with fat before cooking. Extra fat in the oven during roasting will increase splashing and soilage.
- It is not necessary to add water to the meat tin when roasting. The water and the fat juices from the joint create excessive splattering during cooking, even at normal temperatures, as well as causing condensation.
- Covering joints during cooking will also prevent splashing onto the interior surfaces. Removing the covering for the last 20-30 minutes will allow extra browning if required. Some large joints and turkeys especially benefit by this method of cooking, allowing the joint to cook through before the outside is overbrowned.
- **Do use** the trivet in the roasting tin. During roasting the fat from the joint will be contained beneath the trivet and therefore prevent it from splattering onto the Stayclean finish.

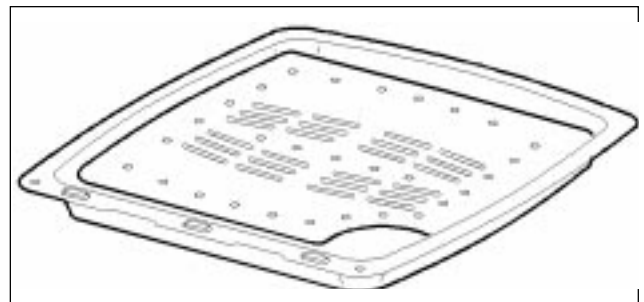
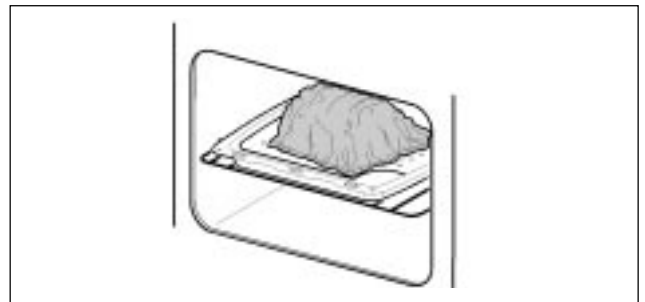

REPLACING THE OVEN LIGHT BULB



Isolate the cooker from the electricity supply before replacing the bulb.

The type of bulb required is a 300°C, 25 watt small Edison Screw.

1. Make sure the cooker is cool before you replace a bulb.
2. Open the oven door and remove the shelves and wirework runners.
Instructions on how to remove the wirework runners are given on page 29.
3. Pull the glass bulb cover towards you and then pull it off. If necessary use a screwdriver to carefully lever off the cover, taking care not to damage the oven cavity.
4. Unscrew the bulb by turning it to the left.
5. Fit a new bulb and then replace the glass bulb cover.
6. Refit the wirework runners and replace the oven shelves.
7. Restore the cooker to the electricity supply and reset the time of day.

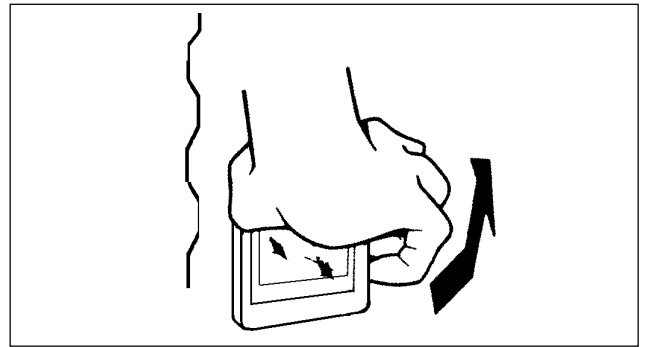

IF SOMETHING DOESN'T WORK

Please carry out the following checks on your cooker before calling a Service Engineer. It may be that the problem is a simple one which you can solve yourself without the expense of a service call.

If our Service Engineer finds that the problem is listed below you will be charged for the call whether or not the cooker is under guarantee.

PROBLEM	POSSIBLE SOLUTION
The grill, ovens and timer do not work	<p>Check that the cooker has been wired in to the cooker supply and is switched on at the wall.</p> <p>Check that the main cooker fuse is working.</p>
The Grill and Top Oven work but the Fan Oven does not.	<p>Check that the timer is set for manual operation. See page 10.</p>
The Grill does not work or cuts out after being used for a long period of time.	<p>Check that only the Grill control has been turned. If the Top Oven control has been turned it will override the grill.</p> <p>Ensure that the grill door is open when grilling. Leave the grill door open and allow the grill to cool. After a couple of hours check that the grill works as normal.</p> <p>Ensure the cooling fan is running when the grill is on. If the cooling fan fails, the grill will not work. Contact your nearest Service Force Centre.</p>
The timer does not work	<p>Check that the instructions for the operation of the timer are being closely followed.</p>
The indicator neons are not working correctly	<p>Check that you have selected only the function you require. Ensure all other controls are in the Off 'O' position.</p>
The oven is not cooking evenly	<p>Check that the cooker is correctly installed and is level.</p> <p>Check that the recommended temperatures and shelf positions are being used.</p>

The oven light fails to illuminate	The oven light bulb may need replacing see page 32. If the Fan Oven is set for automatic cooking the light will illuminate when the cook time begins.
The oven fan is noisy	Check that the oven is level. Check that shelves and bakeware are not vibrating in contact with the oven back panel.
The oven temperature is too high or low	Check that the recommended temperatures and shelf positions are being used. See page 22. Be prepared to adjust up or down by 10°C to achieve the results you want.

GUARANTEE CONDITIONS

Standard guarantee conditions

We, Zanussi, undertake that if within 24 months of the date of the purchase this Zanussi appliance or any part thereof is proved to be defective by reason only of faulty workmanship or materials, we will, at our option repair or replace the same FREE OF CHARGE for labour, materials or carriage on condition that:

- The appliance has been correctly installed and used only on the electricity supply stated on the rating plate
- The appliance has been used for normal domestic purposes only, and in accordance with the manufacturer's instructions
- The appliance has not been serviced, maintained repaired, taken apart or tampered with by any person not authorised by us
- All service work under this guarantee must be undertaken by a local Service Force Centre.
- Any appliance or defective part replaced shall become the Company's property
- This guarantee is in addition to your statutory and other legal rights

Home visits are made between **8.30am** and **5.30pm** Monday to Friday. Visits may be available outside these hours in which case a **premium** will be charged.

Exclusions

This guarantee does not cover:

- Damage or calls resulting from transportation, improper use or neglect, the replacement of any light bulbs or removable parts of glass or plastic
- Costs incurred for calls to put right an appliance which is improperly installed or calls to appliances outside the United Kingdom
- Appliances found to be in use within a commercial environment, plus those which are subject to rental agreements
- Products of Zanussi manufacture which are not marketed by Zanussi

European Guarantee

If you should move to another country within Europe then your guarantee moves with you to your new home subject to the following qualifications:

- The guarantee starts from the date you first purchased your product
- The guarantee is for the same period and to the same extent for labour and parts as exists in the new country of use for this brand or range of products
- This guarantee relates to you and cannot be transferred to another user
- Your new home is within the European Community (EC) or European Free Trade Area
- The product is installed and used in accordance with our instructions and is only used domestically, i.e. a normal household
- The product is installed taking into account regulations in your new country

Before you move please contact your nearest Customer Care centre, listed below, to give them details of your new home. They will then ensure that the local Service Organisation is aware of your move and able to look after you and your appliances.

France	Senlis	+33 (0) 3 44 62 29 99
Germany	Nürnberg	+49 (0) 800 234 7378
Italy	Pordenone	+39 (0) 0434 39 4700
Sweden	Stockholm	+46 (0) 8 672 53 90
UK	Slough	+44 (0) 1753 219897

SERVICE AND SPARE PARTS



In the event of your appliance requiring service, or if you wish to purchase spare parts please contact your local Service Force Centre by telephoning:

0870 5 929929

Your telephone call will be routed to the Service Force Centre covering your post code area. The address are listed on the following pages.

For Service in the **Republic of Ireland** contact
Zanussi
Long Mile Road
Dublin 12

Telephone: 01 4090751

Before calling out an engineer, please ensure you have read the details under the heading 'If Something Doesn't Work'.

When you contact the Service Force Centre you will need to give the following details:

1. Your name, address and post code
2. Your telephone number
3. Clear and concise details of the fault
4. The model and serial number of the appliance (found on the rating plate)
5. The purchase date

CUSTOMER CARE DEPARTMENT

For general enquiries concerning your Zanussi appliance, or further information on Zanussi products, you are invited to contact our Customer Care Department by letter or telephone to the address below or visit our Website at [http:// www.zanussi.co.uk](http://www.zanussi.co.uk)

Customer Care Department
Zanussi
55 - 77 High Street
Slough
Berkshire
SL1 1DZ

Tel: 0870 5 727727 *

(*calls to this number may be recorded for training purposes.)

To contact your local Service Force Centre telephone **08705 929 929**

CHANNEL ISLANDS		NORTH EAST	
GUERNSEY Guernsey Electricity PO Box 4 Vale, Guernsey Channel Islands GY1 3AD	ISLE OF LEWIS ND Macleod 16 James Street Stornoway Isle of Lewis PA87 2QW	GATESHEAD Unit 356a Dukesway Court Dukesway Gateshead NE11 0BH	
JERSEY Jersey Electricity Company Haut de L'orme Rue De Haut De L'orme Trinity Jersey Channel Islands JE3 5FG	KELSO 2, 6 & 8 Woodmarket Kelso Borders TD5 7AX	GRIMSBY 15 Hainton Avenue Grimsby N. E. Lincs DN32 9AS	
SCOTLAND			
ABERDEEN 54 Claremont Street Aberdeen AB10 6RA	PERTH Scottish Hydro Electric Central Warehouse Inveralmond Perth PH1 3AF	HULL Unit 1 Boulevard Industrial Estate Hull HU3 4AY	
AUCHTERMUCHY 33a Burnside Auchtermuchy Fife KY14 7AJ	(OWN SALES)	LEEDS 64-66 Cross Gates Road Cross Gates Leeds LS15 7YS	
BLANTYRE Unit 5 Block 2 Auchenraith Ind. Estate Rosendale Way Blantyre G72 0NJ	SHETLAND 3-4 Carlton Place Lerwick Shetland ZE1 0PW	NEWTON AYCLIFFE Unit 23 Northfield Way Aycliffe Industrial Park Newton Aycliffe DL5 6EJ	
DUMFRIES 93 Irish Street Dumfries DG1 2PQ	(OWN SALES)	SHEFFIELD Pennine House Roman Ridge Road Sheffield S9 1GB	
DUNOON 7 Hill Street, Dunoon Argyll PA23 7AL	SHETLAND Bolts Shetland 26 North Road Lerwick Shetland ZE1 0PE	NORTH WEST	
EDINBURGH Unit 12 Dumbyrden Ind. Estate 2 Dumbyrden Road Edinburgh EH14 2AB	WHALSAY Leask Electrical Harisdale Symbister, Whalsay Shetland ZE2 9AA	BIRKENHEAD 1 Kelvin Park Dock Road Birkenhead CL41 1LT	
GLASGOW Unit 4 Wellington Road Bishopriggs Glasgow G64 2SA	NORTHERN IRELAND		
INVERNESS Unit 3BI Smithton Ind. Estate Smithton Inverness IV2 7WL	BELFAST Owenmore House Kilwee Business Park Dunmurry Belfast BT17 0HD	CARLISLE Unit 7 James Street Workshops James Street Carlisle Cumbria CA2 5AH	
ISLE OF ARRAN R Haggerty Bruach Blackwaterfoot Isle of Arran	WALES		
ISLE OF BARRA J Zerfah 244 Bruernish Isle of Barra Western Islands HS9 5QY	CARDIFF Unit 4 Guardian Industrial Estate Clydesmuir Road Cardiff CF2 2QS	ISLE OF MAN South Quay Ind. Estate Douglas Isle of Man IM1 5AT	
ISLE OF BUTE Walker Engineering Glenmhor Upper Serpentine Road Rothesay Isle of Bute PA20 9EH	CLYWD Unit 6-7 Coed Parc Abergele Road Rhuddlan Clwyd LL18 5UG	BOLDON Unit B Central Industrial Estate St Marks Street Boldon BL3 6NR	
			PRESTON Unit 250 Dawson Place Bamber Bridge Preston Lancashire PR5 8AL
			STOCKPORT Unit 20 Haigh Park Haigh Avenue Stockport SK4 1QR
			OSWESTRY Plas Ffynnon Warehouse Middleton Road Oswestry SY11 2PP

To contact your local Service Force Centre telephone **08705 929 929**

MIDLANDS		LONDON & EAST ANGLIA		SOUTH EAST	
BIRMINGHAM	66 Birch Road East Wyrley Trading Estate Witton Birmingham B6 7DB	BECKENHAM	11a Gardner Ind. Estate Kent House Lane Beckenham Kent BR3 1QZ	ASHFORD	Unit 2 Bridge Road Business Centre Bridge Road Ashford Kent TN23 1BB
BOURNE	Pinfold Road Bourne PE10 9HT	CHELMSFORD	Hanbury Road Widford Ind. Estate Chelmsford Essex CM12 3AE	FLEET	Unit 1 Redfields Ind. Estate Church Crookham Fleet Hampshire GU13 0RD
BRIDGNORTH	68 St.Mary's Street Bridgnorth Shropshire WV16 4DR	COLINDALE	Unit 14 Capitol Park Capitol Way Colindale London NW9 0EQ	HAYWARDS HEATH	21-25 Bridge Road Haywards Heath Sussex RH16 1UA
GLOUCESTER	101 Rycroft Street Gloucester GL1 4NB	ELTHAM	194 Court Road Mottingham Eltham London SE9 4EW	TONBRIDGE	Unit 30 Deacon Trading Estate Morley Road Tonbridge TN9 1RA
HEREFORD	Unit 3 & 4 Bank Buildings Cattle Market Hereford HE4 9HX	ENFIELD	284 Alma Road Enfield London EN3 7BB	SOUTH WEST	
HIGHAMFERRERS	30 High Street Higham Ferrers Northants NN10 8PL	GRAVESEND	Unit B4, Imperial Business Estate West Mill Gravesend Kent DA11 0DL	BARNSTAPLE	Main Road Fremington Barnstaple North Devon EX31 2NT
ILKESTON	Unit 2 Furnace Road Ilkeston DE7 5EP	IPSWICH	Unit 6C Elton Park Business Centre Hadleigh Road Ipswich IP2 0DD	BOURNEMOUTH	63-65 Curzon Road Bournemouth Dorset BH1 4PW
LEICESTER	Unit 7 Oaks Industrial Estate Coventry Road Narborough Leicestershire LE9 5GF	LETCHWORTH	16-17 Woodside Ind. Park Works Road Letchworth Herts SG6 1LA	BRIDGEWATER	6 Herswell Business Park Salmon Parade Bridgewater Somerset TA6 5PY
LINCOLN	Unit 8 Clifton Street Stone Field Park Lincoln LN5 8LQ	LONDON	2 - 4 Royal Lane Yiewsley West Drayton Middlesex UB7 8DL	BRISTOL	11 Eldon Way Eldonwall Trading Estate Bristol BS4 3QQ
NEWCASTLE UNDER LYME	18-21 Croft Road Brampton Ind. Estate Newcastle under Lyme Staffordshire ST5 0TW	MAIDENHEAD	Reform Road Maidenhead Berkshire SL6 8BY	EMSWORTH	266 Main Road Southbourne Emsworth PO10 8JL
REDDITCH	13 Thornhill Road North Moons Moat Redditch Worcestershire B98 9ND	MOLESEY	10 Island Farm Avenue West Molesey Surrey KT8 2UZ	ISLE OF WIGHT	Unit 8 Enterprise Court Ryde Business Park Ryde Isle of Wight PO33 1DB
TAMWORTH	Unit 3 Sterling Park Claymore Tamworth B77 5DQ	NEWBURY	9 Pipers Court Berkshire Drive Thatcham Berkshire RG19 4ER	NEWTON ABBOT	Unit 2 Zealley Ind.Estate Kingsteignton Newton Abbot TQ12 3TD
WORCESTER	Unit 1 & 2 Northbrooks Close Gregorys Mill Ind. Estate Worcester WR3 8BP	NORWICH	2b Trafalgar Street Norwich NR1 3HN	REDRUTH	Unit 7D Pool Ind. Estate Druids Road Redruth Cornwall TR15 3RH
		SUNBURY	Unit 1a The Summit Hanworth Road Sunbury on Thames TW16 5DB		

TECHNICAL DETAILS

Voltage: 230\240 Volts AC 50Hz

Loading Info:

Top Oven* 1.7kW

Dual Grill: 2.8kW

Single Grill 1.4kW

Main Oven
Fan Element: 2.5kW

Fan Motor: 0.03kW

Oven Light: 0.05kW

Wattage: 5.0\5.5kW

Height: 720 mm

Width: 593 mm

Weight: 50 kg

Depth: 585 mm
(excluding handles and knobs)

* Cannot be used at the same time as the grill element

This appliance complies with: European Council Directive 73/23/EEC.
EMC Directive 89/336/EEC.
CE Marking Directive 93/68/EEC.

INSTALLATION INSTRUCTIONS

THINGS YOU NEED TO KNOW



WARNINGS:

WARNINGS:

- This cooker must be installed by a qualified electrician/competent person. Safety may be impaired if installation is not carried out in accordance with these instructions.
- This cooker must be earthed.
- **Do not** remove the screws from the earth tab extending from the oven mains terminal block (Fig. 1).
- Before connecting the cooker make sure that the voltage of your electricity supply is the same as that indicated on the rating plate. The rating plate can be seen by opening the top oven door and looking below the oven door seal.
- **Do not** alter the electrical circuitry of this cooker.

CHOICE OF ELECTRICAL CONNECTION

- The cooker should be operated using at least 6mm² twin core and earth PVC insulated multicore cable. Please choose from the most appropriate after reading the descriptions:
- By connecting the cooker to a cooker point having a double pole isolating switch providing at least 3mm contact separation in all poles and protected with a fuse or miniature circuit breaker at your mains fuse box.
- If you wish to connect an oven and a hob to a cooker point you can, by connecting the oven and hob separately to the cooker point. See Fig. 2.

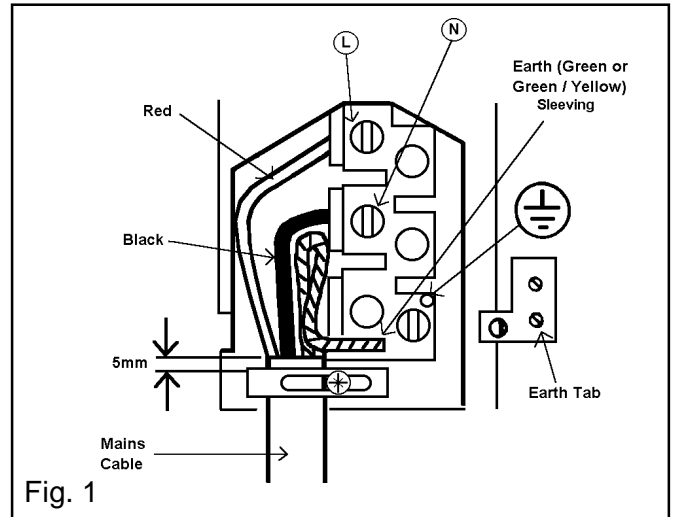

Fig. 1

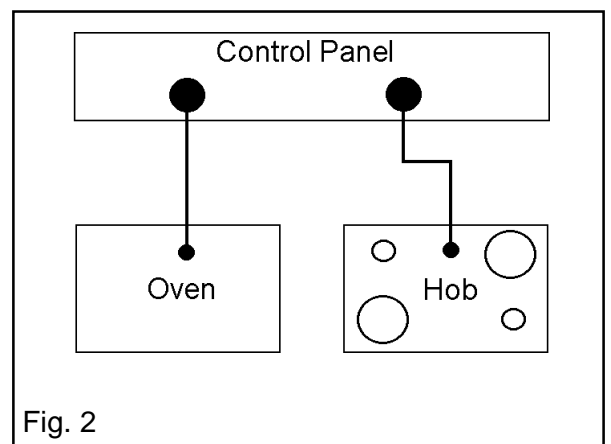

Fig. 2

INSTALLATION INSTRUCTIONS

NOTE: It is good practice to:

- Fit an Earth Leakage Circuit Breaker to your house wiring.
- Wire your appliance to the latest IEE regulations.

THINGS TO NOTE

- This cooker is designed to be fitted between cabinets with the recommended dimensions as shown in Fig. 3 & 4.
- If there is an existing housing unit it must be removed.
- The dimensions given provide adequate air circulation around the unit within the cabinet, ensuring compliance with BS EN60-335.
- This appliance must not be installed on a wooden base board.
- Enquiries regarding the installation of the cooker point if required should be made to your Regional Electricity Company to ensure compliance with their regulations.
- The cooker point should be within 2m of the cooker to make it accessible to switch off the cooker in case of an emergency.
- To protect the hands wear gloves when lifting the oven into its housing.

NOTE: HOUSE CIRCUIT

Earth leakage / continuity tests must be carried out before the cooker is connected to the mains supply and re-checked after fitting.

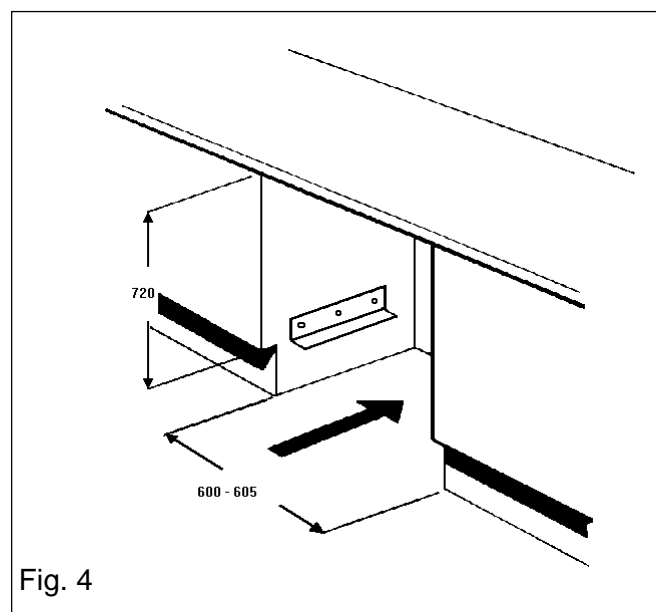
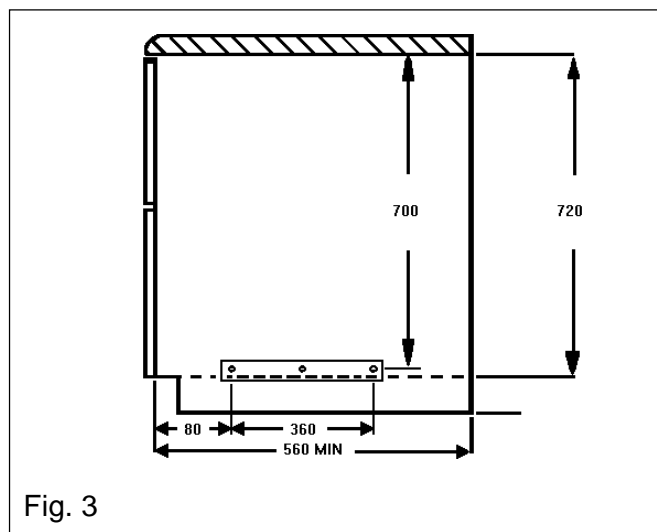

INSTALLATION INSTRUCTIONS

PREPARING CABINET FOR FITTING OVEN

- Make sure the space between the cabinets is the correct size for the appliance to be fitted (Ref. Fig. 5 & 6).
- The plinth board spanning the space into which the appliance is to be installed should be removed.

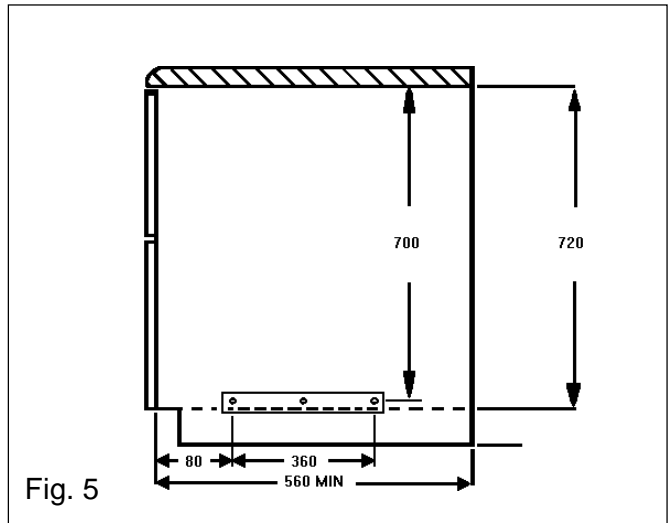

Fig. 5

- If the size between adjacent cabinets is 605-610*mm, then the cabinets should be modified so that the recommended dimension of at least 600-605mm is maintained.
- The adjacent cabinets must be stable and firmly secured to the wall or floor. If necessary, make arrangements to ensure the work surface below which the oven will rest is level.
- Drill two pilot screw holes into the sides of the adjacent cabinets, in the positions indicated by Fig. 5.

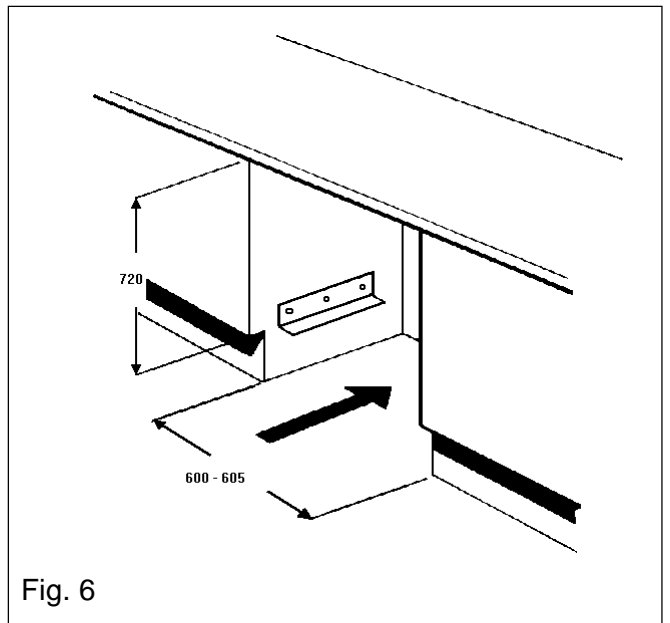

Fig. 6

- Fit the appliance mounting brackets using the two holes indicated in Fig. 7 to the adjacent cabinets (Ref. Fig.5 & 6)

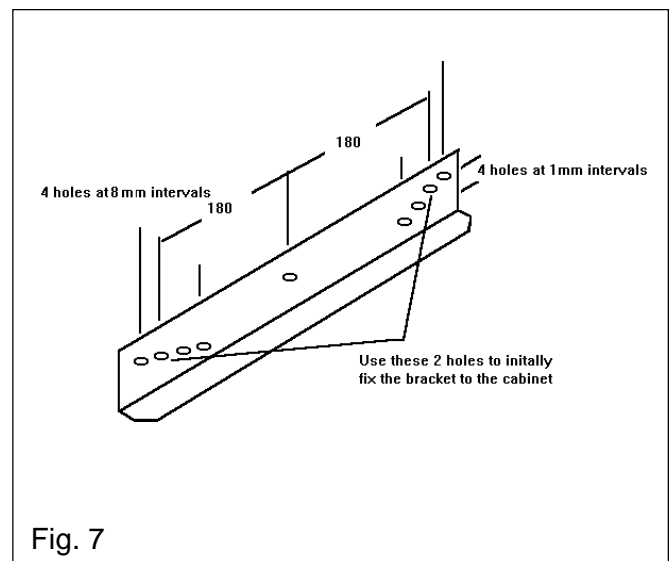

Fig. 7

INSTALLATION INSTRUCTIONS

- Check that the mounting brackets are level. They can be adjusted if necessary by using the extra holes at the ends of the brackets. Once the brackets are level, drill a pilot hole through the central hole in the bracket and fit the remaining screw

HOW TO FINISH UNPACKING

- Place packed cooker next to the space in which it will be installed. See Fig. 8.
- Remove the cooker packing except for bottom tray which should be left in position until the cooker is ready to be fitted into its cabinet.
- Ensure the owner is given these operating instructions.

NOTE: It is imperative that the appliance is left in the base to protect both the appliance and the floor.

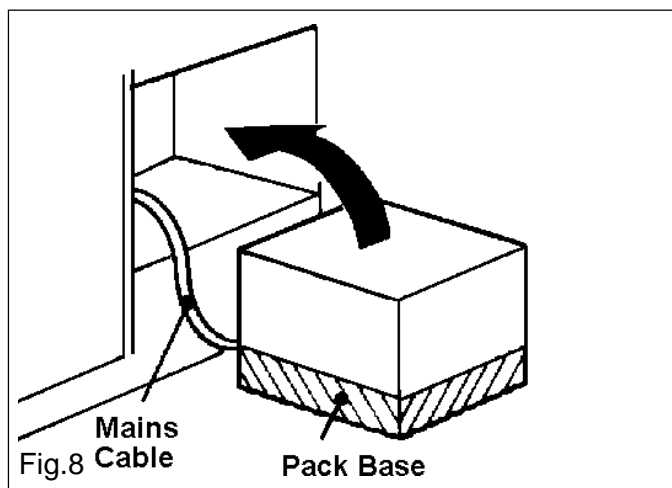

Important: Switch off at mains, miniature circuit breaker and, if appropriate, remove fuse before commencing any electrical work.

INSTALLATION INSTRUCTIONS

TO REMOVE COVER OF MAINS TERMINAL

From the rear of the cooker, remove mains input terminal cover to gain access to terminal block.

- First remove retaining screw with pozidrive screwdriver. See Fig. 9.

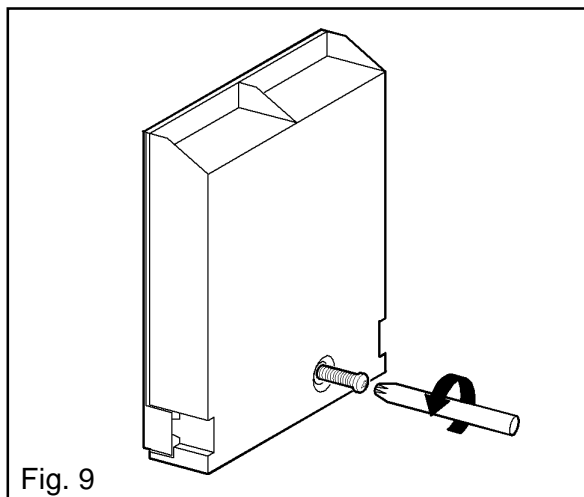

- Prise cover loose using screwdriver in position (1) then lever off with screwdriver in position (2) at either side. See Fig. 10.

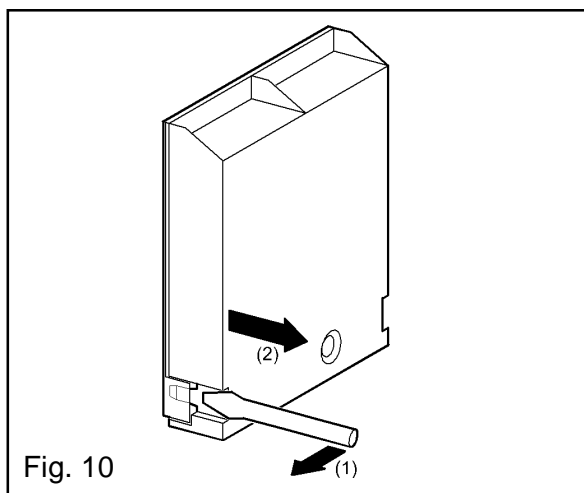

- Lift cover and remove screw from cable clamp. See Fig. 11.

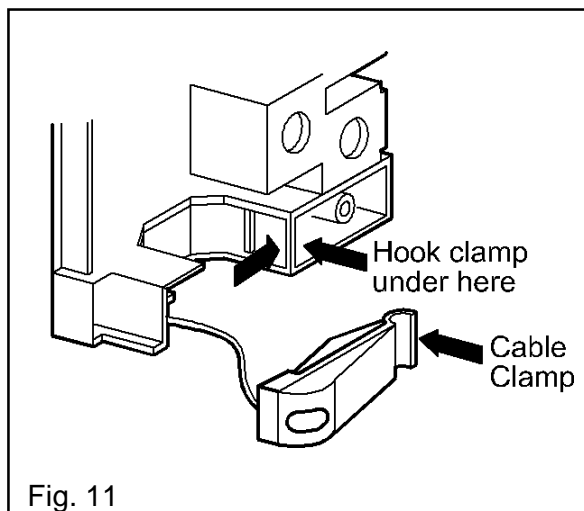

INSTALLATION INSTRUCTIONS

CONNECTING TO THE MAINS TERMINAL



Warning: This cooker must be earthed.

- We recommend you use a new length of 6mm² twin core and earthed cable to ensure your safety.
- Make connection as shown in Fig. 12 by proceeding as follows:-
- Preform wires to the appropriate shape to suit fitting into the mains terminal block.
- Strip inner insulation on wires using wirestrippers.
- Twist the bared wires using pliers.
- Cut bared wires 10mm away from the end of the inner insulation. Where uninsulated Earth wires are used ensure they are suitably sheathed to leave 10mm bare wire to fit into the terminal.
- Clamp bare wires into the relevant terminal and check they are held by tugging each one in turn.
- Clamp the mains cable securely ensuring 5mm of the outer insulation is inside the terminal block and that the wires are not taught but not so slack as to cause any fouling. See Fig. 12.
- Connect the remaining end of the mains cable to the cooker point / junction box
- Place fuse / miniature circuit breaker in circuit and switch on at mains.

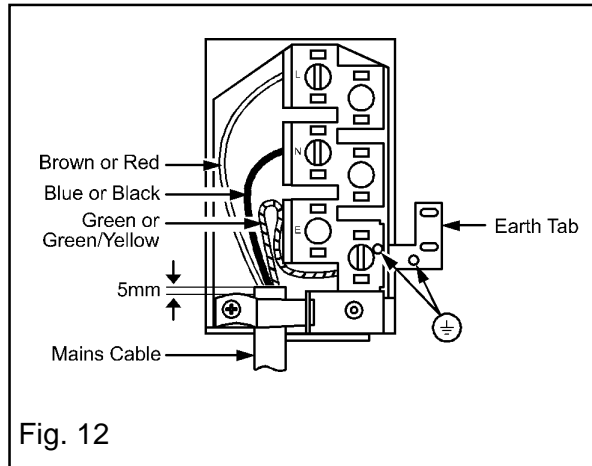

Fig. 12

INSTALLATION INSTRUCTIONS

CHECKING ELECTRICAL CONNECTIONS

- Confirm the cooker is correctly connected by switching on and observing the various oven functions indicators.
- The electronic timer will flash on and off.

CONNECTING TO A HOB OR COOKER POINT

- Either follow in general terms the instructions for connecting to the terminal block or refer to the hob suppliers installation instructions.

Feed the cable through the cabinet and arrange to route the cable away from the cooker.

NOTE: HOUSE CIRCUIT

Earth leakage / continuity tests must be carried out before the cooker is connected to the mains supply and re-checked after fitting.

INSTALLATION INSTRUCTIONS

FITTING INTO THE SPACE BETWEEN CABINETS



IMPORTANT: Ensure that the oven is switched off at the wall before any further work is carried out.

- Ensure the cooker is in front of the cabinet. See Fig. 13.
- Take out all oven furniture before installation to reduce the weight you need to lift.
- To place the cooker into the space between cabinetry follow the procedure below:
- **N.B. Two people will be required to carry out the lifting procedure.**
Warning: **Do not** attempt to lift this appliance by the handle(s).
- Each person should squat either side of the cooker.
Tilt the cooker so that your hands can support the underside of the cooker.
Raise the appliance to the correct height.
Rest the rear underside of the cooker on the mounting brackets while your hands support the front.
The cooker can be pushed fully into the space. Take care to avoid fouling the mains lead.
Ensure the cooker is central and level.
- When the cooker is fully housed, screw the stability screws (supplied with the cooker) into the underside of the worksurface in the positions indicated (see Fig. 14), taking care not to distort the trim. It is advisable to turn each screw alternately to avoid damaging the trim.
- Place the top trim flush with the edge of the worksurface, with the cork spacers upover (see Fig.15) and screw into position using the screws supplied with the cooker.
- Replace the plinth board.
- Switch on the cooker and refer the user to the operating instructions.

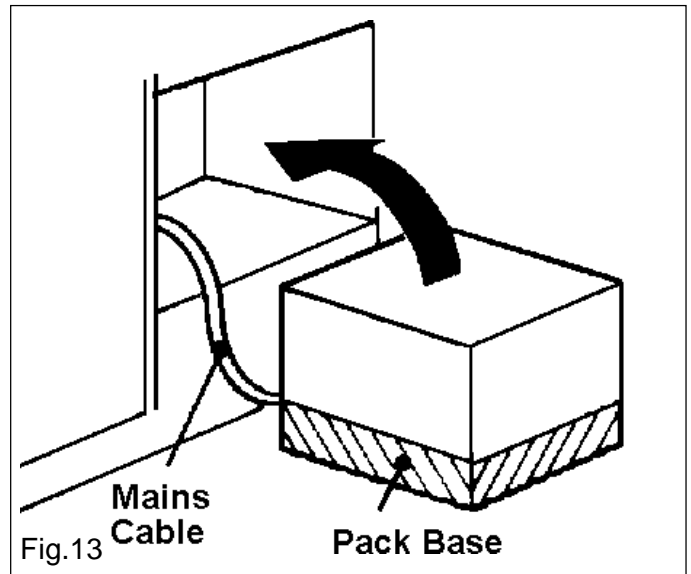

Fig.13

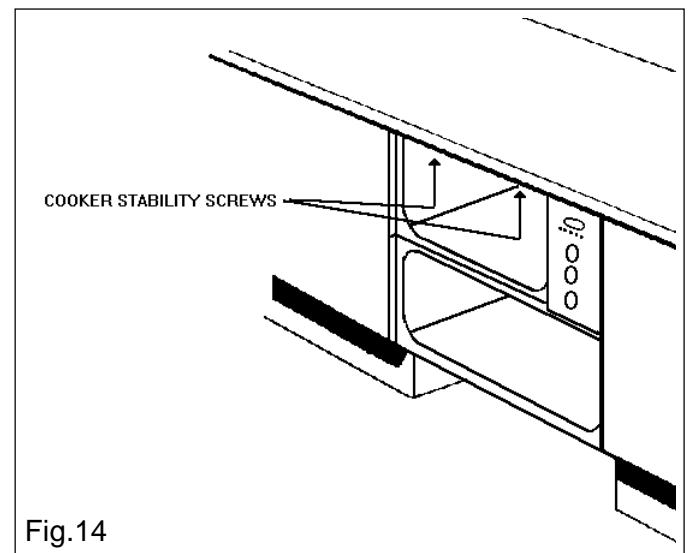

Fig.14

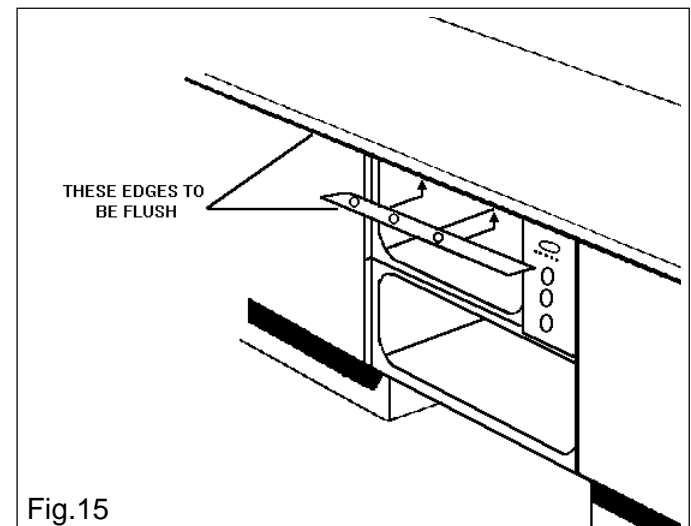

Fig.15

NOTES

RATING PLATE REFERENCE

MAKE AND MODEL NO.	SERIAL NO.	DATE OF PURCHASE	PRODUCT NO.

IMPORTANT NOTICE

In line with our continuing policy of research and development, we reserve the right to alter models and specifications without prior notice.

This handbook is accurate at the date of printing, but will be superseded and should be disregarded if specifications or appearance are changed.

ZANUSSI
55 - 77 HIGH STREET,
SLOUGH,
BERKSHIRE,
SL1 1DZ
TELEPHONE 0870 5 727727
<http://www.zanussi.co.uk>

Part Number:311455607



© Electrolux Household Appliances Limited 2001

 **From the Electrolux Group.** *The world's No.1 choice.*

The Electrolux Group is the world's largest producer of powered appliances for kitchen, cleaning and outdoor use. More than 55 million Electrolux Group products (such as refrigerators, cookers, washing machines, vacuum cleaners, chain saws and lawn mowers) are sold each year to a value of approx. USD 14 billion in more than 150 countries around the world.

This file has been downloaded from:

www.UsersManualGuide.com

User Manual and User Guide for many equipments like mobile phones, photo cameras, mother board, monitors, software, tv, dvd, and othes..

Manual users, user manuals, user guide manual, owners manual, instruction manual, manual owner, manual owner's, manual guide, manual operation, operating manual, user's manual, operating instructions, manual operators, manual operator, manual product, documentation manual, user maintenance, brochure, user reference, pdf manual