

# TRICITY BENDIX

INSTRUCTION BOOK

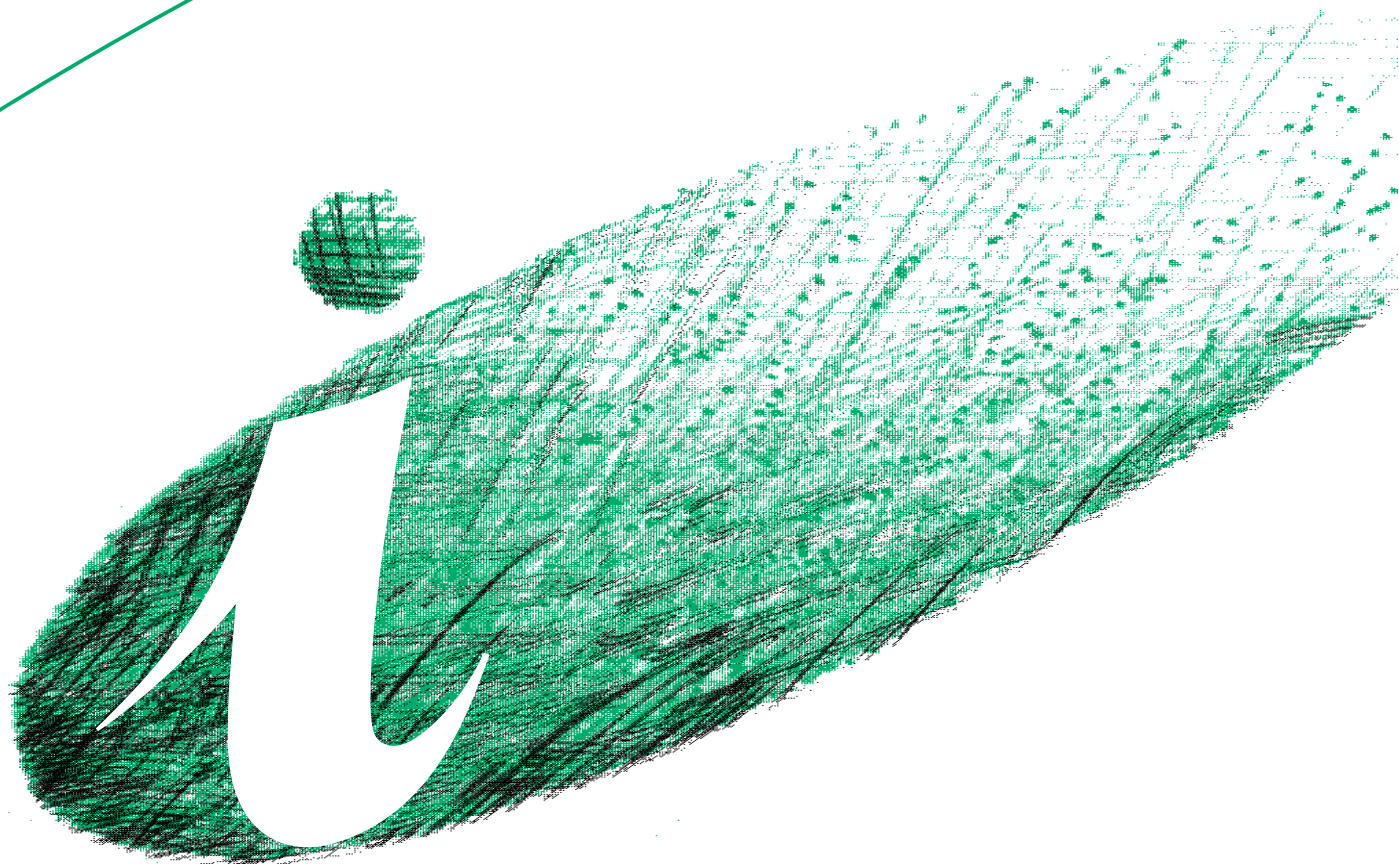

Dishwasher

***DH 102***

# Description of the appliance

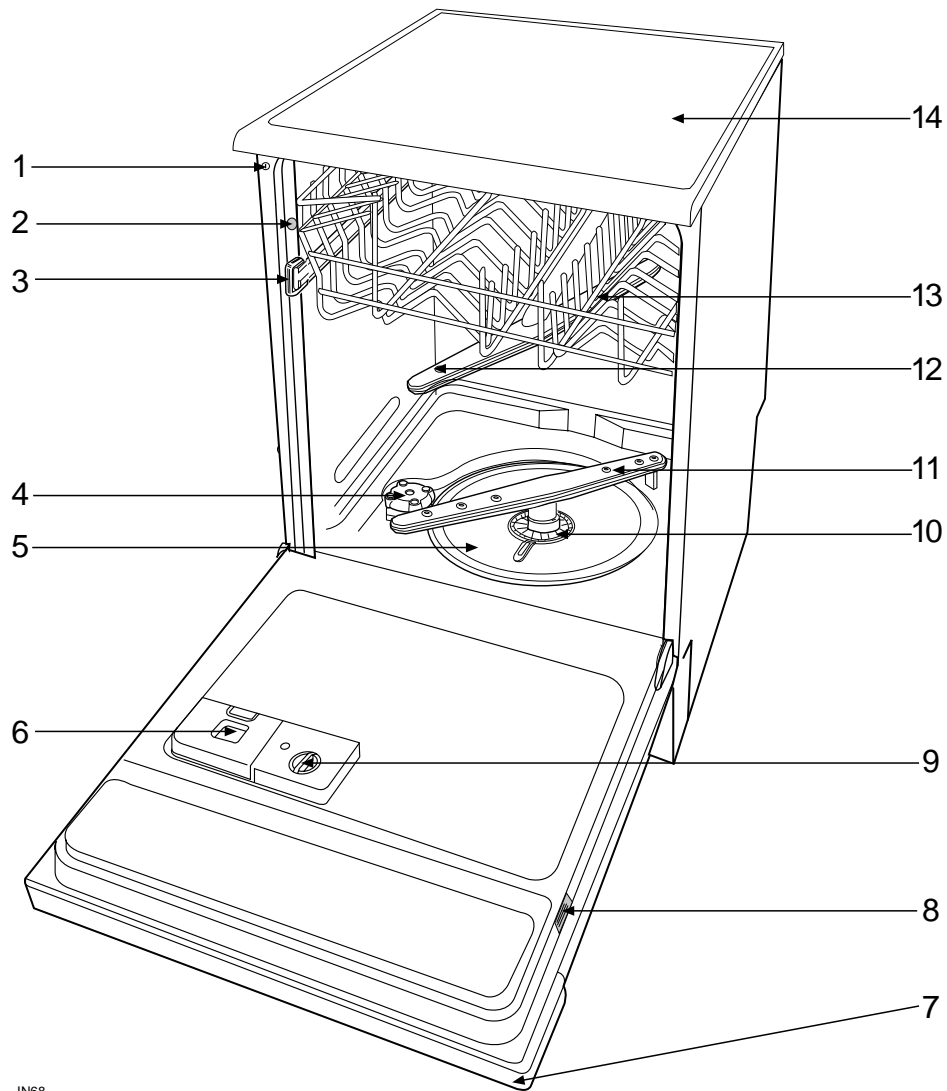

IN68

- |                              |                        |
|------------------------------|------------------------|
| 1. Water hardness adjustment | 9. Rinse aid dispenser |
| 2. Levelling spacers         | 10. Central filter     |
| 3. Upper basket stop         | 11. Lower spray arm    |
| 4. Salt container            | 12. Upper spray arm    |
| 5. Large filter              | 13. Upper basket       |
| 6. Detergent dispenser       | 14. Worktop            |
| 7. Control panel             |                        |
| 8. Rating plate              |                        |

# The control panel

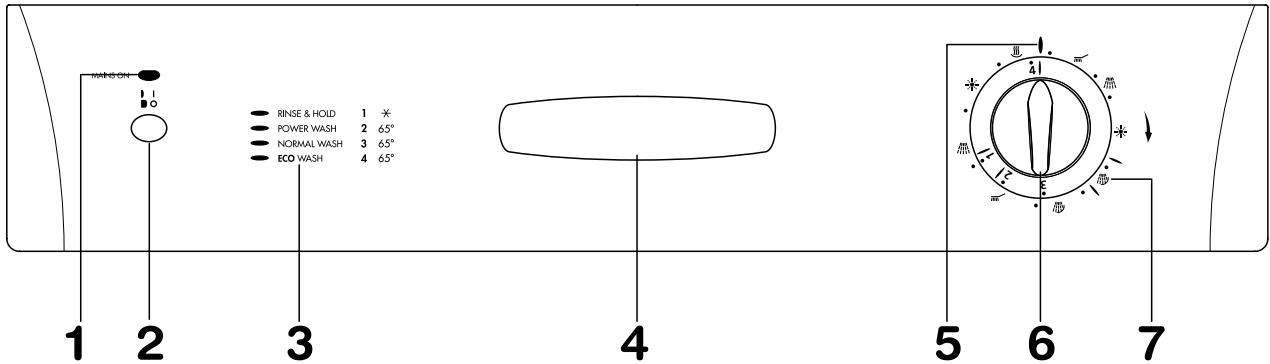

**1. MAINS ON indicator light**

**2. On/Off push button**

**3. Programme guide**

**4. Door handle**

**5. Programme marker**

**6. Programme selector dial**

**7. Programme sequence indicator**

As the programme progresses, the programme selector dial turns, to show the phase in the wash programme the appliance has reached.

 Prewash / Rinse and Hold

 Wash

 Cold rinse

 Hot rinse

 Drying

# Washing programmes

Programme	Degree of soil and type of load	Starting position of the programme selector	Required push button	Recommended quantity of detergent		Cycle description
				Wash	Prewash	
<b>RINSE &amp; HOLD</b>	Any. Partial load (to be completed later in the day).	<b>1</b>	<b>On/Off</b>	/	/	1 cold rinse (to avoid food scraps from sticking together).
<b>* POWER WASH</b>	Normal soil Crockery and cutlery	<b>2</b>	<b>On/Off</b>	25 g	5 g	Cold prewash Main wash up to 65°C 1 cold rinse 1 hot rinse Drying
<b>NORMAL WASH</b>	Light soil Crockery and cutlery	<b>3</b>	<b>On/Off</b>	30 g	/	Main wash up to 65°C 1 cold rinse 1 hot rinse Drying
<b>** ECO WASH</b>	Light soil Crockery, cutlery and party crockery	<b>4</b>	<b>On/Off</b>	30 g	/	Main wash up to 65°C 1 cold rinse 1 hot rinse

\* Testing programme for EN 50242 (see "Hints for Test Centres").

\*\* This is a special programme for quick washing a full load of lightly soiled dishes, glasses and crockery (except pots) so that you may re-use them promptly.

# Operating sequence

## 1. Check the filters

Ensure they are clean and properly positioned  
See "Maintenance and cleaning" section.

## 2. Check that there is rinse aid and salt

See "Before Use" section.

## 3. Load the dishes

Remove any scraps of food.

Pull the lower basket out and arrange the saucepans, plates and cutlery in it.

Pull the upper basket out and arrange the plates, saucers, glasses and cups etc. in it.

Slide the baskets back into the machine.

## 4. Ensure that the spray arms can rotate freely.

## 5. Measure out detergent

Add the required amount of detergent into the dispenser according to the "Washing programmes" chart.

Close the detergent dispenser lid.

## 6. Close the dishwasher door

## 7. Set the programme

Turn the programme selector dial clockwise until the number of the programme you wish to select corresponds with the programme marker on the control panel.

## 8. Start the programme

Depress the On/Off push button.

The MAINS ON indicator light will come on and the machine will start.

If you wish to interrupt the washing programme at any time open the door and press this button again.

## 9. At the end of the washing programme

At the end of the programme the dishwasher will automatically stop.

## 10. Switch off the dishwasher

Switch off the dishwasher by pressing the On/Off push button.



**Wait 15/20 minutes before opening the dishwasher's door; in this way you will avoid burning yourself when removing the dishes and avoid also the damage of the nearby furniture caused by the escape of steam.**

Empty the lower basket first and then the upper one; this will avoid water dripping from the upper basket onto the dishes in the lower one.



---

**When the washing programme has finished, it is recommended that the dishwasher is unplugged and the water tap turned off.**

**In general it is not advisable to open the door while the machine is working; if the door is opened however, a safety device ensures that the machine stops.**

---



---

**Important!**  
**Care must be taken if the door is opened during the hot phase or immediately after a programme has finished, as steam may escape.**

---

# Using your appliance

## Loading your appliance

Before placing dishes in the machine, remove any scraps of food, to avoid clogging the filters and consequently reducing the performance.

---

**i** Do not load very small items which can fall through the baskets.

---

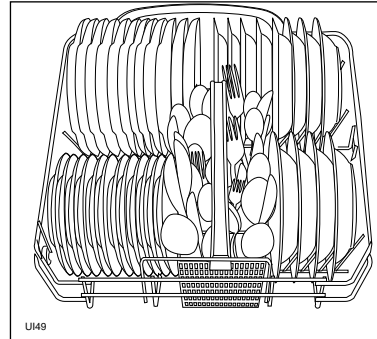

## The lower basket

The lower basket is designed to take saucepans, lids, plates, salad bowls, cutlery etc.

Serving dishes and large lids should be arranged around the edge of the basket, ensuring that the upper spray arm can turn freely.

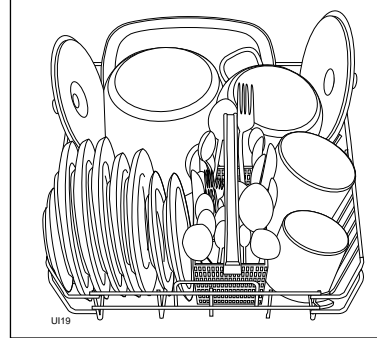

## The cutlery basket

---

**!** Long bladed knives stored in an upright position are a potential hazard.  
Long and/or sharp items of cutlery such as carving knives must be positioned horizontally in the upper basket.  
Take care when loading or unloading sharp items such as knives.

---

Cutlery should be placed in the removable cutlery basket with the handles facing downwards.

If the handles protrude from the bottom of the basket, obstructing the lower spray arm, load the cutlery with the handles facing upwards.

Mix spoons with other cutlery to prevent them from sticking together.

Arrange spoons, dessert spoons, knives and other small items of cutlery in the rack on the side of the cutlery basket.

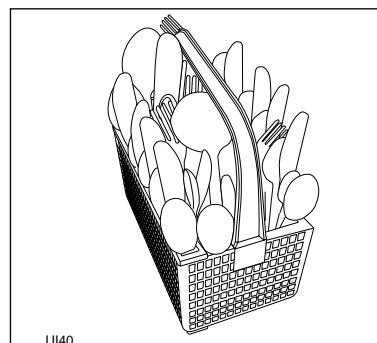

## The upper basket

The upper basket is designed for plates (dessert plates, saucers, dinner plates of up to 25 cm in diameter), salad bowls, cups and glasses.

Arrange items so that water can reach all surfaces.

Light items (plastic bowls etc.) should be loaded in the upper basket and arranged so they do not move.

### ***In case that plates are loaded in the upper basket:***

*load them starting from the rear positions of the basket; tilting them slightly forwards and avoiding the front positions near the door.*

---

**i** Before closing the door, ensure that the spray arms can rotate freely.

---

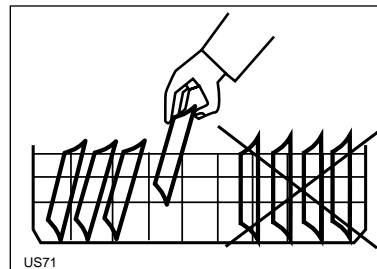
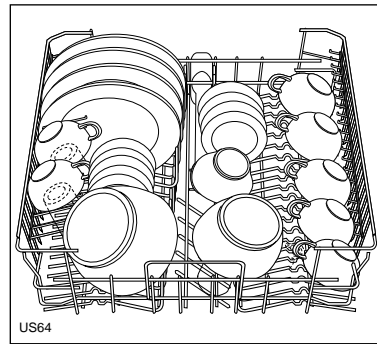

## Adjusting the height of the upper basket

If washing very large plates (over 27 cm and up to 32 cm in diameter) you can load them in the lower basket after moving the upper basket to the higher position.

**To move to the higher position proceed as follows:**

1. Move the front runner stops (A) of the upper basket outwards and slide the basket out.
2. Refit the basket in the higher position and replace the stops (A) in their original position.

---

**i** When the top basket is in the higher position it will only take plates up to 20 cm in diameter and you will not be able to use the cup rack.

---

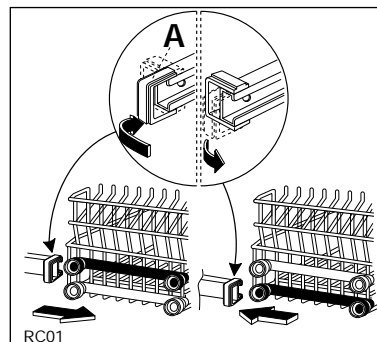

---

**!** After loading your machine always close the door, as an open door can be a hazard.

---

# Hints for test centres

Before starting any test it is necessary to fill completely with salt the salt container and with rinse aid the rinse aid dispenser

Test standard:	EN 50242
Reference programme:	NORMAL WASH
Load:	12 standard place settings
Rinse aid selector:	position 5
Detergent dosage:	25 g in the dispenser 5 g on the dispenser lid



Arrangement  
upper basket

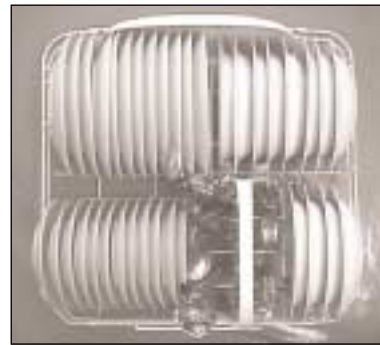

Arrangement  
lower basket

## Technical specifications

Dimensions	Width	60 cm
	Height with worktop	85 cm
	Height without worktop	82 cm
	Max depth	61 cm
	Max depth with open door	115.2 cm
Electrical connection Motor rating during wash Power of heating element Overall power	Voltage	220/240 V - 50 Hz
		200 W
		2100 W
		2300 W
Water supply pressure	Minimum	50 kPa (0.5 bar)
	Maximum	800 kPa (8 bar)
Capacity		12 place settings



## Fitting under a counter

(kitchen worktop or sink)

By removing the machine's worktop, you can install it under a close fitting sink unit or a pre-existing top, providing the dimensions of the recess correspond to those shown in the picture.

### Proceed as follows:

- Remove the machine's worktop by unscrewing the two rear retaining screws, pull from the front and slide out the rear slots, lifting the worktop.

Insert the machine after adjusting height and levelling with the adjustable feet. When inserting the machine, ensure that the water inlet and drain hoses are not kinked or squashed.

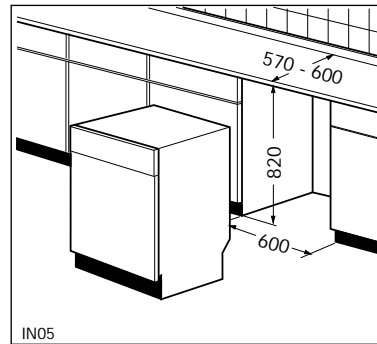

## Levelling

Good levelling is essential for correct closure and sealing of the door.

When the appliance is correctly levelled, the door will not catch on the levelling spacers on either side of the cabinet.

If the door does not close correctly, loosen or tighten the adjustable feet until the machine is perfectly level.

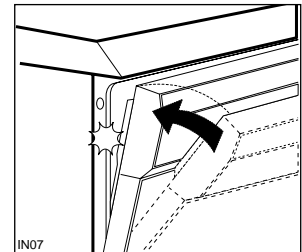
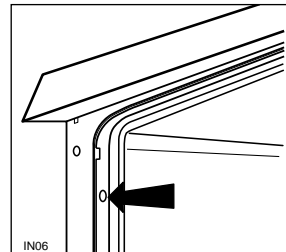

# TRICITY BENDIX

Tricity Bendix, 55-77 High Street, Slough, Berkshire, SL1 1DZ

**Customer care telephone number...**  
**08705 950 950**



**From the Electrolux Group. The world's No.1 choice.**

*The Electrolux Group is the world's largest producer of powered appliances for kitchen, cleaning and outdoor use. More than 55 million Electrolux Group products (such as refrigerators, cookers, vacuum cleaners, chain saws and lawn mowers) are sold each year to a value of approx. 14 billion USD in more than 150 countries around the world.*



- **Before use**
- **Maintenance**
- **Installation**

## DISHWASHER

## Contents

<b>Important safety information</b>	2
<b>Before use</b>	3
Setting the water softener	3
Filling with salt	4
Filling with rinse aid and adjusting the dose	5
Use of detergent	6
<b>Hints and tips</b>	7
<b>Maintenance and cleaning</b>	8
Internal cleaning	8
Cleaning the filters	8
External cleaning	8
Prolonged periods of non-operation	8
Frost precautions	8
Moving the machine	8
<b>Something not working</b>	9
<b>Installation</b>	10
Water supply connections	10
Water outlet connection	10
Electrical connection	11

### Guide to use the instruction book



**Safety instructions**

**1. 2. 3. Step by step**



**Hints and tips**



**Environmental information**



# Important safety information

**It is most important that this instruction book should be retained with the appliance for future reference. Should the appliance be sold or transferred to another owner, or should you move house and leave the appliance, always ensure that the book is left with the appliance in order that the new owner can get to know the functioning of the appliance and the relevant safety information.**

**This information has been provided in the interest of your safety. You MUST read it carefully before installing or using the appliance.**

## Installation

- This appliance is heavy. Care should be taken when moving it.
- It is dangerous to alter the specifications or attempt to modify this product in any way.
- Care must be taken to ensure that the appliance does not stand on the electrical supply cable.
- Any electrical work required to install this appliance should be carried out by a qualified electrician or competent person.
- Any plumbing work required to install this appliance should be carried out by a qualified plumber or competent person.

## Child Safety

- This appliance is designed to be operated by adults. Children should not be allowed to tamper with the controls or play with the product.
- Keep all packaging well away from children.
- Keep all detergents in a safe place out of children's reach.

## During Use

- Items that are contaminated by petrol, paint, steel or iron debris, corrosive, acidic or alkaline chemicals must not be washed in this dishwasher.
- Under no circumstances should you open the door whilst the appliance is in operation. Always turn off the appliance before opening the door.
- Only use detergent specifically designed for use in dishwashers.
- Long bladed knives stored in an upright position are a potential hazard.
- Long and/or sharp items of cutlery such as carving knives must be positioned horizontally in the upper basket.
- When finishing loading or unloading close the door, as an open door can be a hazard.
- Do not sit or stand on the open door.
- Isolate the appliance from the power supply and turn off the water supply after use.
- Care should be taken when cleaning the bottom door seal and hinge area as any exposed metal edges may cut if care is not taken.

- This product should be serviced by an authorised Service engineer, and only genuine spare parts should be used.
- Under no circumstances should you attempt to repair the machine yourself. Repairs carried out by inexperienced persons may cause injury or serious malfunctioning. Contact your local Service Force Centre. Always insist on genuine spare parts.

## Conservation

### In the interest of the environment:

- Materials marked with the symbol  are recyclable.
- Check with your local Council or Environmental Health Office to see if there are facilities in your area for re-cycling this appliance.
- When the appliance is to be scrapped, cut off the power supply cable and make the door closing device unusable to prevent young children from being trapped inside.
- Help to keep your country tidy - use authorised disposal sites for your old appliance.

# Before use

## Before using your dishwasher for the first time:

1. Ensure that the electrical and water connections comply with the installation instructions
2. Remove all packaging from inside the appliance
3. Set the water softener
4. Pour 1 litre of water inside the salt container and then fill with salt
5. Fill the rinse aid dispenser.
6. Run a "Rinse and Hold" programme.

## Setting the water softener

The dishwasher is equipped with a water softener designed to remove minerals and salts from the water supply, which would have a detrimental or adverse effect on the operation of the appliance.

The higher the content of these salts, the harder your water is.

Water hardness is measured in equivalent scales, Clarke, French degrees and PPM (parts per Million).

The softener should be adjusted according to the hardness of the water in your area. Your local Water Authority can advise you on the hardness of the water in your area.

The dishwasher is factory set at level 2.

If this level is not suitable for your area the softener should be adjusted.

## To adjust the water softener

With a screwdriver turn the selector on the upper front corner of the machine until the level required corresponds with the marker.

Water hardness			Level	Use of salt
Clarke degrees	French degrees (°TH)	PPM (Parts per Million)		
0 - 6	0 - 8	0 - 80	0	NO
7 - 14	9 - 20	81 - 200	1	YES
15 - 28	21 - 40	201 - 400	2	YES
29 - 42	41 - 60	401 - 600	3	YES
43 - 56	61 - 80	601 - 800	4	YES
57 - 63	81 - 90	801 - 900	5	YES



**If your water is level 0 it is already soft and therefore there is no need to use salt. In this case adjust the water softener on level 1 without using salt.**

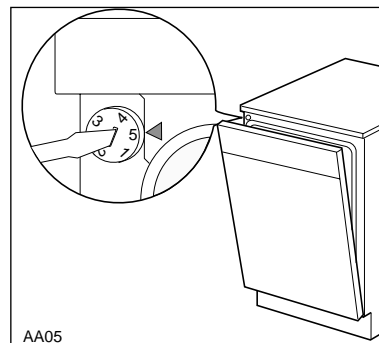

## Filling with salt



### Attention!

Only use salt specifically designed for use in dishwashers. All other types of salt not specifically designed for use in dishwasher, especially table salt, will damage the water softener. Only fill with salt just before starting a washing programme. This will prevent any grains of salt or salty water, which may have been spilled, remaining on the bottom of the machine, which may cause corrosion.

The salt container will require topping up periodically.

According to the model, an indicator reminds you when filling with salt:

- A) The salt cap has a **refill indicator window** in the centre. A **green float** is clearly visible when there is salt inside the container, and almost disappears when the salt has finished reminding you to add salt.

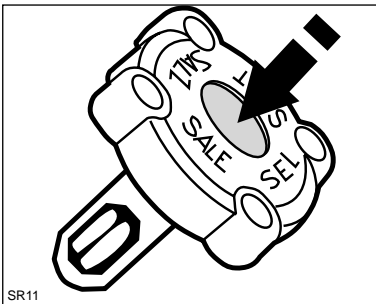

- B) A **salt indicator light** on the control panel will come on when the salt has finished.



The salt indicator light on the control panel can remain illuminated for 2-6 hours after the salt has been replenished, assuming the dishwasher remains switched on. If you are using salts that take longer to dissolve then this can take longer. The function of the machine is not affected..

Do not worry if water over flows from the unit when filling with salt, this is quite normal.

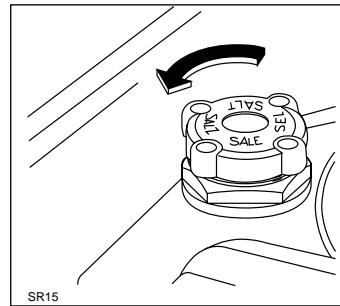

1. Unscrew the cap of the salt container.

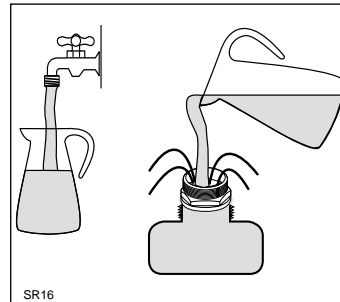

2. Pour 1 litre of water inside the container (this is necessary only before filling with salt for the first time).

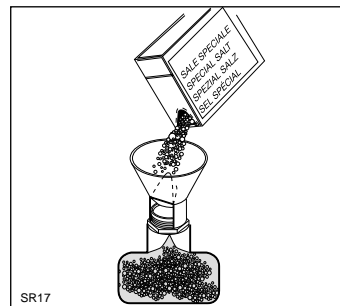

3. Using the funnel provided, pour in the salt until the container is full.



4. Remove any trace of salt on the screw thread or on the gasket.

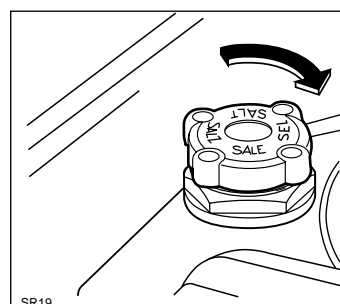

5. Screw on the cap tightly.

## Rinse aid

Rinse aid is automatically added during the last rinse, ensuring thorough rinsing, and spot and streak free drying. The dispenser, which is positioned inside the door, holds about 110 ml of rinse aid, which is sufficient for 16 - 40 dishwashing programmes, depending upon the dosage setting.

### Filling with rinse aid

1. Open the container by turning the lid (A) anticlockwise.
2. Add the rinse aid until the container is completely full. The indicator (B) will be completely dark.
3. Top up the rinse aid when the indicator (B) becomes clear.

#### (Only for models with rinse aid indicator light)

Top up with rinse aid when the rinse aid indicator light on the control panel illuminates.

**Ensure that the lid is closed after every refill.**

Do not put liquid detergent in the rinse aid compartment. Clean up any rinse aid spilt during filling with an absorbent cloth to avoid excess foaming during the next wash.

### Adjusting the dose

According to the finish and drying results obtained, adjust the dose of rinse aid by means of the 6 position selector (C) (position 1 minimum dosage, position 6 maximum dosage). Increase the dose if there are drops of water or lime spots on the dishes after washing.

Reduce it if there are sticky whitish streaks on the dishes.

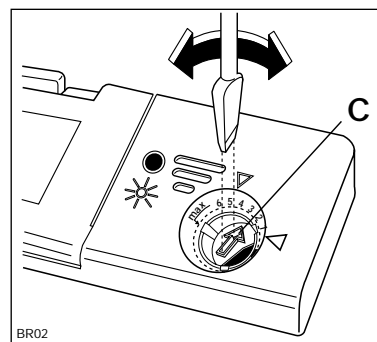
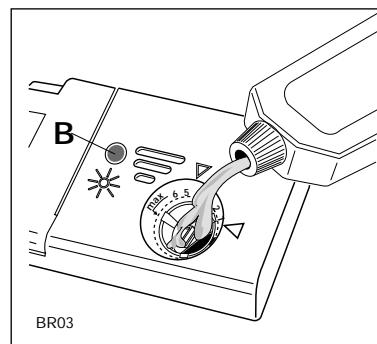
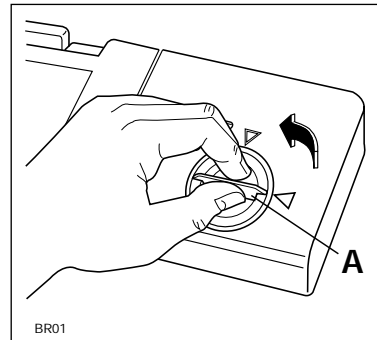

## Use of detergent

---

**i** Only use detergents specifically designed for use in dishwashers.

---

We recommend the use of **Finish** detergents which are available in the following options:

**Finish Double Action Tablets.** Each tablet has the exact amount of detergent required, simply place in the dispenser.

**Finish Powder** recommended for every day use.

**Finish Liquid Gel** ideal for every day use. As the gel is extra gentle it is recommended for fine bone china.

### If using powder detergents proceed as follows:

1. Open the dispenser lid by pulling the catch (D).
2. Add the detergent according to the recommended quantity given in the "Washing programmes" chart.

As all detergents are not the same, you should also consult the instructions on the packet.

3. Always close the lid.
4. If the programme has a prewash add a little amount of detergent over the lid of the dispenser. Follow the recommended quantity given in the "Washing programmes" chart.

### If using detergent in tablets proceed as follows:

1. For all programmes; place 1 tablet inside the detergent dispenser.
2. Always close the lid.
3. For all programmes with prewash; place a portion of a further tablet on the lid of the detergent dispenser.

**If your dishwasher has a SID dispenser and you require a prewash, put the extra detergent into the SID dispenser and not on the lid of the detergent dispenser.**



Insufficient quantities of detergent will produce poor washing results, whereas an excessive amount of detergent will not improve washing results and is also wasteful. Using no more than the correct amount also contributes to reducing pollution.

---

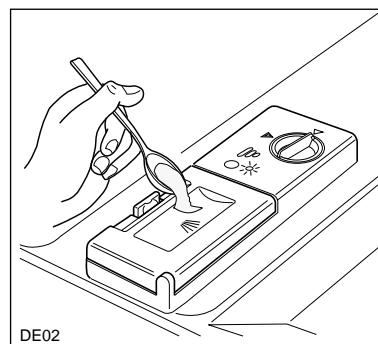
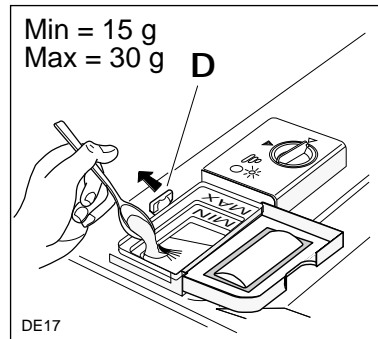

## Compact detergents with enzymes

In these compact powders the environmentally unfriendly components have been replaced by natural enzymes and other more biodegradable substances.

The enzymes deploy their full dirt dissolving power at a temperature as low as 50°C.

By choosing the 50°C programmes (**if available**) you can therefore achieve the same cleaning results that would otherwise be achievable only with 65°C programmes and conventional detergents.

These new compact powders are generally phosphate-free.



# Hints and tips

## To save energy

Place dishes in the machine immediately after every meal and wait until the dishwasher is full before washing.

If necessary run the Rinse and Hold programme (see "Washing Programmes" chart) so that any food scraps do not become caked on the dishes while you are waiting to run the complete wash programme.

Do not prewash dishes under running water.

## For best washing and drying results

Before loading, remove all scraps of food and soak very heavily soiled pots and pans.

Arrange saucepans, cups and glasses etc. upside-down.

Tilt items with convex or concave surfaces so that the water drains off easily.

Avoid contact between the dishes as far as possible.

## Items not suitable for dishwashers

**The following items should not be washed in the dishwasher (unless they are sold as dishwasher proof):**

- Cutlery with wooden or horn handles or glued parts
- bronze cutlery
- saucepans with wooden handles
- aluminium ware
- crystal ware
- leaded glass
- plastic items
- antique or fine decorated china

Certain types of decoration can discolour when washed in a dishwasher.

Crystal-ware and plastic objects, if not guaranteed dishwasher proof should be washed by hand.

Certain types of glass can also become opaque after being washed several times in a dishwasher.

A chemical reaction can occur between silver cutlery and stainless steel cutlery. As a precaution, do not wash together.

Iron and cast iron objects can rust and stain other items.

Aluminium tends to go black, copper, pewter and brass tend to stain.

---

**i** If in doubt check with manufacturer of the item. When buying new dishes, ensure that they are dishwasher proof.

---

For best results we recommend the use of Finish detergents, rinse aid and salt.



DE15

# Maintenance and cleaning

## Internal cleaning

Ensure that the seals around the door, the detergent and rinse aid dispensers are cleaned regularly with a damp cloth.

We recommend the use of **Finish Dishwasher Cleaner** every 3 months or run a 65°C wash without dishes using detergent. Regular use of **Finish Dishwasher Cleaner** cleans inaccessible parts, eliminates unpleasant food odours and helps prevent the build-up of limescale.

## Cleaning the central filter

(After each wash)

Scraps of food may accumulate in the drain filter (A) and should be removed by rinsing the filter under running water.

To remove the drain filter

- simply pull it out by the handle.

Once cleaned, refit the filter by pushing it back to its original position until it engages.

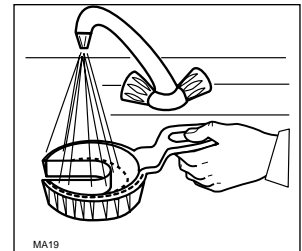
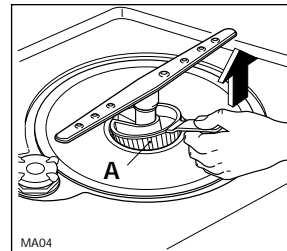

## Cleaning the large filter

(Every week)

If necessary clean the large filter (B) on both sides under running water, using a brush.

To remove the large filter

1. Remove the spray arm by pulling it upwards on one side.
2. Turn the column (C) anticlockwise by 90° and then slide out the filter.
3. Once cleaned refit it following the above instructions in reverse order.
4. Ensure the filter is in its original position, the handle of the drain filter should be pointing towards the front of the appliance.

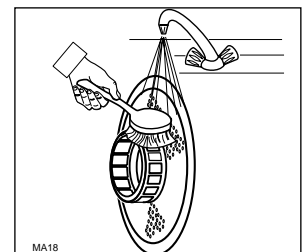
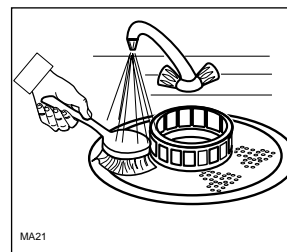
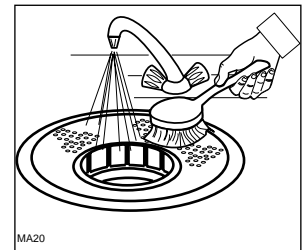
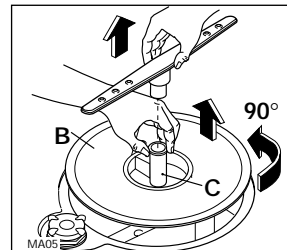

**The dishwasher must not be used without filters. Incorrect repositioning and fitting of the filters will produce poor washing results. Cleaning the filters is vital to ensure correct operation of the machine.**

## External cleaning

Clean the external surfaces of the machine and control panel with a damp soft cloth. If necessary use only neutral detergents. Never use abrasive products, scouring pads or solvent (acetone, trichloroethylene etc....).

## Prolonged periods of non-operation

If you are not using the machine for any period of time you are advised to:

1. Unplug the appliance and then turn off the water.
2. Fill the rinse aid dispenser.
3. Leave the door ajar to prevent the formation of any unpleasant smells.
4. Leave the inside of the machine clean.

## Frost precautions

Avoid placing the machine in a location where the temperature is below 0°C. If this is unavoidable, empty the machine, close the appliance door, disconnect the water inlet pipe and empty it.

## Moving the machine

If you have to move the machine (moving house etc....):

1. Unplug it.
  2. Turn the water tap off.
  3. Remove the water inlet and discharge hoses.
  4. Pull the machine out together with the hoses.
- Avoid over tilting the machine during transportation.

# Something not working

Certain problems are due to lack of simple maintenance or oversights, which can be solved easily without calling out an engineer.

Before contacting your local Service Force Centre, please carry out the checks listed below.

**Important:** If you call out an engineer to a fault listed below or to repair a fault caused by incorrect use or installation a charge will be made even if the appliance is in guarantee.

Symptom	Solution
The machine will not start	<ul style="list-style-type: none"> <li>The door has not been properly closed.</li> <li>The plug is not properly inserted in the power socket.</li> <li>There is a power failure.</li> </ul>
The machine does not fill with water	<ul style="list-style-type: none"> <li>Ensure the water tap is open.</li> <li>Ensure the mains water supply has not been cut off.</li> <li>The inlet hose may be squashed or bent. Reposition the hose.</li> <li>The inlet hose may be blocked. Switch off the water supply and clean the filter.</li> </ul>
The filters are blocked	<ul style="list-style-type: none"> <li>Clean the filters (refer to "Maintenance and cleaning").</li> </ul>
The spray arms are not rotating	<ul style="list-style-type: none"> <li>Ensure the crockery is loaded correctly.</li> </ul>
The dishwasher will not drain	<ul style="list-style-type: none"> <li>The drain hose may be squashed or bent. Reposition the hose.</li> <li>The sink may be blocked. Clear any blockages.</li> <li>The drain hose extension is not correct. Follow the instructions for connecting to the waste.</li> <li>There is no vent in the end of the drain hose.</li> </ul>
The machine is noisy	<ul style="list-style-type: none"> <li>Dishes are rattling against each other, refer to "Loading your machine".</li> <li>The spray arms are knocking against the dishes. Refer to "Loading your machine".</li> </ul>
The door is difficult to close	<ul style="list-style-type: none"> <li>The dishwasher is not level, or not properly built-in.</li> </ul>
Visible lime deposits or white film on the dishes	<ul style="list-style-type: none"> <li>Check that there is salt and that the salt cap is tight.</li> <li>Check that the right level of the water softener is set.</li> </ul>
The dishes are not quite dry	<ul style="list-style-type: none"> <li>The rinse aid has run out or too little is being used.</li> </ul>
The dishes are not clean (poor wash)	<ul style="list-style-type: none"> <li>The baskets are too full.</li> <li>The dishes have not been arranged properly.</li> <li>The spray arms do not rotate</li> <li>The spray arms are clogged.</li> <li>The filters are clogged.</li> <li>The filters are not in the correct position.</li> <li>Not enough detergent has been used or it is unsuitable.</li> <li>The detergent is old or has gone hard.</li> <li>The salt container cap is not properly closed.</li> <li>The washing programme selected is too gentle.</li> </ul>

If after all these checks, the problem persists, contact your local Service Force Centre, quoting the model and serial number. This information can be found on the rating plate located on the right hand side of the dishwasher door.

**i** This product should be serviced by an authorised Service engineer, and only genuine spare parts should be used. Under no circumstances should you attempt to repair the machine yourself. Repairs carried out by inexperienced persons may cause injury or serious malfunctioning. Contact your local Service Force Centre. Always insist on genuine spare parts.

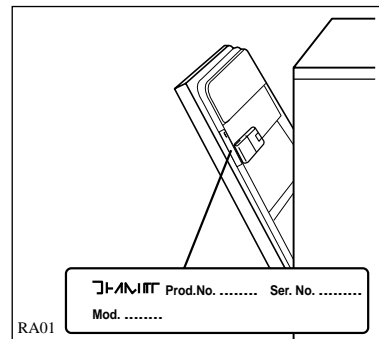

# Installation

 **Any electrical work required to install this appliance should be carried out by a qualified electrician or competent person.**

**Any plumbing work required to install this appliance should be carried out by a qualified plumber or competent person.**

**Remove all packaging before positioning the machine.**

If possible, position the machine next to a water tap and a drain.

## Levelling

Good levelling is essential for correct closure and sealing of the door. When the appliance is correctly levelled, the door will not catch on the levelling spacers on either side of the cabinet. If the door does not close correctly, loosen or tighten the adjustable feet until the machine is perfectly level.

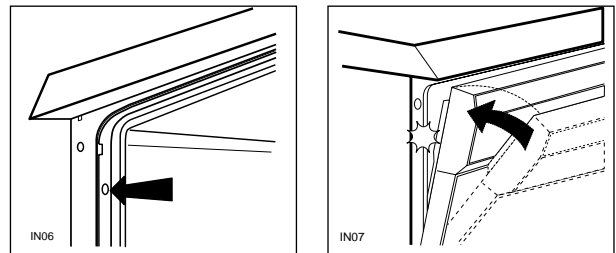

## Water supply connections

This dishwasher must be plumbed into a cold water supply. The water pressure must be within the limits given in the "Technical specifications" section.

Your local Water Authority will advise you on the average mains pressure in your area.

The dishwasher features fill and drain hoses which can be turned either to the left or the right to suit the installation.

Do not use, for connection, old hoses which have been used in another appliance.

**The locknut must be correctly fitted to avoid water leaks.**

Avoid bends or kinks in the hose which could prevent or slow down the water supply.

If the machine is connected to new pipes or pipes which have not been used for a long time, you should run the water for a few minutes before connecting the inlet hose. This will prevent deposits of sand or rust clogging the inlet hose.

## Water outlet hose connection

The end of the drain hose can be connected in the following ways:

1. To the sink outlet spigot, securing it if necessary with a clip.

 **Attention!**  
**Our appliances are supplied with a with a security device to protect against the return of dirty water back into the machine.**  
**If the spigot of your sink has a "no return valve" incorporated this can prevent the correct draining of your dishwasher. We advise you therefore to remove it.**

2. Hooked over the edge of the sink using the special curved plastic guide (if provided).
3. To a stand pipe provided with vent-hole, minimum internal diameter 4 cm.

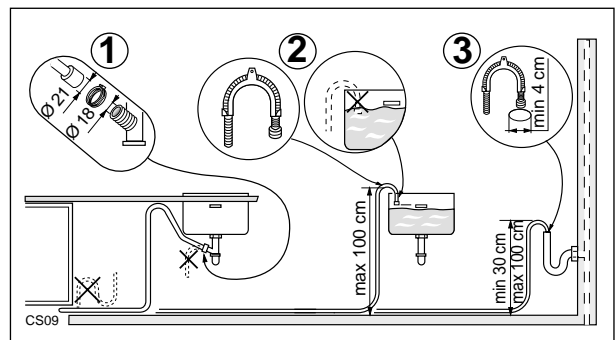

The waste connection must be at a height of between 30 cm (minimum) and 100 cm (maximum) from the bottom of the dishwasher.

The drain hose can face either to the right or left of the dishwasher

Ensure the hose is not bent or squashed as this could prevent or slow down the discharge of water.

If you use a drain hose extension it must be no longer than 2 metres and its internal diameter must be no smaller than the diameter of the hose provided.

Likewise the internal diameter of the couplings used for connections to the waste outlet must be no smaller than the diameter of the hose provided.

The sink plug must not be in place when the machine is draining as this could cause the water to siphon back into the machine.

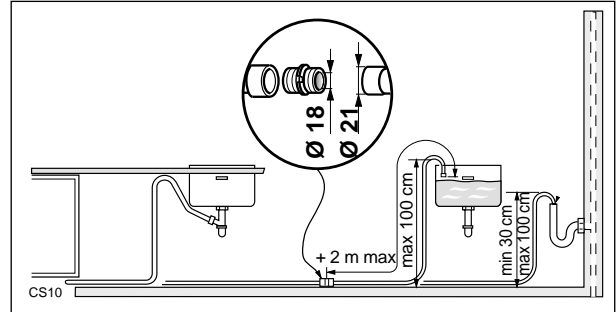

## Electrical connection



**This appliance must be earthed.**  
**The manufacturer declines any responsibility should this safety measure not be observed.**

If the plug that is fitted to your appliance is not suitable for the socket, it must be cut off and the appropriate plug fitted.

### Important

The wires on the mains lead are coloured in accordance with the following code:

**Green and Yellow** -Earth  
**Blue** -Neutral  
**Brown** -Live

If you fit your own plug, the colours of the wires in the mains lead of your appliance may not correspond with the markings identifying the terminals in your plug.

### Proceed as follows:

1. Connect the Green and Yellow (earth) wire to the terminal in the plug which is marked with the letter "E" or the earth symbol  $\oplus$  or coloured green and yellow.
2. Connect the Blue (neutral) wire to the terminal in the plug which is marked with the letter "N" or coloured black.
3. Connect the Brown (live) wire to the terminal in the plug which is marked with the letter "L" or coloured red.

The plug moulded onto the lead incorporates a 13amp BSI362 fuse. Only ASTA or BSI fuses should be used.

The plug must not be used if the fuse cover/carrier is lost. The cover/carrier is indicated by the coloured insert at the base of the product.

A replacement cover/carrier must be obtained from your local Service Force Centre.

**This appliance complies with the following E.E.C. Directives:**

- 73/23 or 19.2.73 (Low Voltage Directive) and subsequent modifications;
- 89/336 or 3.5.89 (Electromagnetic Compatibility Directive) and subsequent modifications.

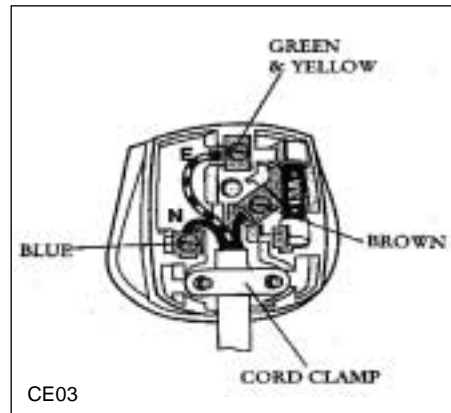

# Service and spare parts

In the event of your appliance requiring service, or if you wish to purchase spare parts please contact your local Tricity Bendix Service Centre by telephoning:

**08705 929 929**

Your telephone call will be automatically routed to the Service Force centre covering your post code area. The addresses are listed on the following pages. Before calling out an engineer, please ensure you have read the details under the heading "Something Not Working".

When you contact the Service Force Centre you will need to give the following details:

1. Your name, address and post code
2. Your telephone number
3. Clear and concise details of the fault
4. The model and serial number (found on the rating plate)
5. The purchase date

## Customer Care Department

For general enquiries concerning your Tricity Bendix appliance or for further information on Tricity Bendix products please contact our Customer Care Department by letter or telephone at the address below.

Customer Care Department

Tricity Bendix  
55-77 High Street  
Slough  
Berkshire  
SL1 1DZ

Tel: 08705 950 950 (\*)

\* calls to this number may be recorded for training purposes



To contact your local Service Force Centre telephone **08705 929 929**

<p><b>CHANNEL ISLANDS</b></p> <p><b>GUERNSEY</b> Guernsey Electricity PO Box 4 Vale, Guernsey Channel Islands GY1 3AD</p> <p><b>JERSEY</b> Jersey Electricity Company Haut De L'orme Rue De Haut De L'orme Trinity Jersey Channel Islands JE3 5FG</p>	<p><b>ISLE OF LEWIS</b> ND Macleod 16 James Street Stornoway Isle of Lewis PA87 2QW</p> <p><b>KELSO</b> 2, 6 &amp; 8 Woodmarket Kelso Borders TD5 7AX</p> <p><b>ORKNEY</b> 7 King Street Kirkwall Orkney KW15 1JF</p>	<p><b>NORTH EAST</b></p> <p><b>GATESHEAD</b> Unit 356a Dukesway Court Dukesway Gateshead NE11 0BH</p> <p><b>GRIMSBY</b> 15 Hainton Avenue Grimsby N. E. Lincs DN32 9AS</p> <p><b>HULL</b> Unit 1 Boulevard Industrial Estate Hull HU3 4AY</p>
<p><b>SCOTLAND</b></p> <p><b>ABERDEEN</b> 54 Claremont Street Aberdeen AB10 6RA</p> <p><b>AUCHTERMUCHTY</b> 33a Burnside Auchtermuchty Fife KY14 7AJ</p> <p><b>BLANTYRE</b> Unit 5 Block 2 Auchenraith Ind. Estate Rosendale Way Blantyre G72 0NJ</p> <p><b>DUMFRIES</b> 93 Irish Street Dumfries DG1 2 PQ</p> <p><b>DUNOON</b> 7 Hill Street Dunoon Argyll PA23 7AL</p>	<p><b>PERTH</b> Scottish Hydro Electric Central Warehouse Inveralmond Perth PH1 3AF (OWN SALES)</p> <p><b>SHETLAND</b> 3-4 Carlton Place Lerwick Shetland ZE1 0PW (OWN SALES)</p> <p><b>SHETLAND</b> Bolts Shetland 26 North Road Lerwick Shetland ZE1 0PE (OWN SALES)</p> <p><b>WHALSAY</b> Leask Electrical Harisdale Symbister, Whalsay Shetland ZE2 9AA (OWN SALES)</p>	<p><b>LEEDS</b> 64-66 Cross Gates Road Cross Gates Leeds LS15 7YS</p> <p><b>NEWTON AYCLIFFE</b> Unit 23 Northfield Way Aycliffe Industrial Park Newton Aycliffe DL5 6EJ</p> <p><b>SHEFFIELD</b> Pennine House Roman Ridge Road Sheffield S9 1GB</p>
<p><b>EDINBURGH</b> Unit 12 Dumbryden Ind. Estate 2 Dumbryden Road Edinburgh EH14 2AB</p> <p><b>GLASGOW</b> Unit 4 Wellington Road Bishopriggs Glasgow G64 2SA</p> <p><b>INVERNESS</b> Unit 3BI Smithton Ind. Estate Smithton Inverness IV2 7WL</p> <p><b>ISLE OF ARRAN</b> Arran Domestic The Douglas Centre Broddick Isle of Arran KA27 8AJ</p> <p><b>ISLE OF BARRA</b> J Zerfah 244 Bruernish Isle of Barra Western Islands HS9 5QY</p> <p><b>ISLES OF BUTE</b> Walker Engineering Glenmhor Upper Serpentine Road Rothesay Isle of Bute PA20 9EH</p>	<p><b>NORTHERN IRELAND</b></p> <p><b>BELFAST</b> Owenmore House Kilwee Business Park Dunmurry Belfast BT17 0HD</p> <p><b>WALES</b></p> <p><b>CARDIFF</b> Unit 4 Guardian Industrial Estate Clydesmuir Road Cardiff CF2 2QS</p> <p><b>CLYWD</b> Unit 6-7 Coed Parc Abergele Road Rhuddlan Clwyd LL18 5UG</p> <p><b>DYFED</b> Unit 9 St. Clears Business Park Tenby Road St. Clears Carmarthen SA33 4JW</p> <p><b>OSWESTRY</b> Plas Ffynnon Warehouse Middleton Road Oswestry SY11 2PP</p>	<p><b>NORTH WEST</b></p> <p><b>BIRKENHEAD</b> 1 Kelvin Park Dock Road Birkenhead CH41 1LT</p> <p><b>CARLISLE</b> Unit 7 James Street Workshops James Street Carlisle Cumbria CA2 5AH</p> <p><b>ISLE OF MAN</b> South Quay Ind. Estate Douglas Isle of Man IM1 5AT</p> <p><b>BOLTON</b> Unit B Central Industrial Estate St Marks Street Bolton BL3 6NR</p> <p><b>PRESTON</b> Unit 250 Dawson Place Bamber Bridge Preston Lancashire PR5 8AL</p> <p><b>STOCKPORT</b> Unit 20 Haigh Park Haigh Avenue Stockport SK4 1QR</p>

**To contact your local Service Centre telephone 08705 929 929**

<b>MIDLANDS</b>		<b>LONDON &amp; EAST ANGLIA</b>		<b>SOUTH EAST</b>	
BIRMINGHAM	66 Birch Road East Wyrley Trading Estate Witton Birmingham B6 7DB	BECKENHAM	11a Gardner Ind. Estate Kent House Lane Beckenham Kent BR3 1QZ	ASHFORD	Unit 2 Bridge Road Business Centre Bridge Road Ashford Kent TN23 1BB
BOURNE	Pinfold Road Bourne PE10 9HT	CHELMSFORD	Hanbury Road Widford Ind. Estate Chelmsford Essex CM12 3AE	FLEET	Unit 1 Redfields Ind. Estate Church Crookham Fleet Hampshire GU13 0RD
BRIDGNORTH	68 St. Mary's Street Bridgnorth Shropshire WV16 4DR	COLINDALE	Unit 14 Capitol Park Capitol Way Colindale London NW9 0EQ	HAYWARDS HEATH	21-25 Bridge Road Haywards Heath Sussex RH16 1UA
GLOUCESTER	101 Rycroft Street Gloucester GL1 4NB	ELTHAM	194 Court Road Mottingham Eltham London SE9 4EW	TONBRIDGE	Unit 30 Deacon Trading Estate Morley Road Tonbridge TN9 1RA
HEREFORD	Units 3 & 4 Bank Buildings Cattle market Hereford HE4 9HX	ENFIELD	284 Alma Road Enfield London EN3 7BB	<b>SOUTH WEST</b>	
HIGHAM FERRERS	30 High Street Higham Ferrers Northants NN10 8PL	GRAVESEND	Unit B4 Imperial Business Estate West Mill Gravesend Kent DA11 0DL	BARNSTAPLE	Main Road Fremington Barnstaple North Devon EX31 2NT
ILKESTON	Unit 2 Furnace Road Ilkeston DE7 5EP	IPSWICH	Unit 6C Elton Park Business Centre Hadleigh Road Ipswich IP2 0DD	BOURNEMOUTH	63-65 Curzon Road Bournemouth Dorset BH1 4PW
LEICESTER	Unit 7 Oaks Industrial Estate Coventry Road Narborough Leicestershire LE9 5GF	LETCHWORTH	16-17 Woodside Ind. Park Works Road Letchworth Herts SG6 1LA	BRIDGEWATER	6 Herswell Business Park Salmon Parade Bridgwater Somerset TA6 5PY
LINCOLN	Unit 8 Clifton Street Stone Field Park Lincoln LN5 8LQ	LONDON	2 - 4 Royal Lane Yiewsley West Drayton Middlesex UB7 8DL	BRISTOL	11 Eldon Way Eldonwall Trading Estate Bristol BS4 3QQ
NEWCASTLE UNDER LYME	18-21 Croft Road Brampton Ind. Estate Newcastle under Lyme Staffordshire ST5 0TW	MAIDENHEAD	Reform Road Maidenhead Berkshire SL6 8BY	EMSWORTH	266 Main Road Southbourne Emsworth PO10 8JL
REDDITCH	13 Thornhill Road North Moons Moat Redditch Worcestershire B98 9ND	MOLESEY	10 Island Farm Avenue West Molesey Surrey KT8 2UZ	ISLE OF WIGHT	Unit 8 Enterprise Court Ryde Business Park Ryde Isle of Wight PO33 1DB
TAMWORTH	Unit 3 Sterling Park Claymore Tamworth B77 5DQ	NEWBURY	9 Pipers Court Berkshire Drive Thatcham Berkshire RG19 4ER	NEWTON ABBOT	Unit 2 Zealley Ind. Estate Kingsteignton Newton Abbot TQ12 3TD
WORCESTER	Units 1 & 2 Northbrooks Close Gregorys Mill Ind. Estate Worcester WR3 8BP	NORWICH	2b Trafalgar Street Norwich NR1 3HN	REDRUTH	Unit 7D Pool Ind. Estate Druids Road Redruth Cornwall TR15 3RH
		SUNBURY	Unit 1a The Summit Hanworth Road Sunbury on Thames TW16 5DB		



# Guarantee conditions

## Standard guarantee conditions

We, Tricity Bendix, undertake that if within 12 months of the date of purchase this Tricity Bendix appliance or any part thereof is proved to be defective by reason only of faulty workmanship or materials, we will, at our option repair or replace the same FREE OF CHARGE for labour, materials or carriage on condition that:

- The appliance has been correctly installed and used only on the electricity supply stated on the rating plate.
- The appliance has been used for normal domestic purposes only, and in accordance with the manufacturer's instructions.
- The appliance has not been serviced, maintained repaired, taken apart or tampered with by any person not authorised by us.
- All service work under this guarantee must be undertaken by a Tricity Bendix Service Force Centre.
- Any appliance or defective part replaced shall become the Company's property.
- This guarantee is in addition to your statutory and other legal rights.

Home visits are made between **8.30am** and **5.30pm** Monday to Friday. Visits may be available outside these hours in which case a **premium** will be charged.

## Exclusions

**This guarantee does not cover:**

- Damage or calls resulting from transportation, improper use or neglect, the replacement of any light bulbs or removable parts of glass or plastic.
- Costs incurred for calls to put right an appliance which is improperly installed or calls to appliances outside the United Kingdom.
- Appliances found to be in use within a commercial environment, plus those which are subject to rental agreements.
- Products of Tricity Bendix manufacture which are not marketed by Tricity Bendix.

## European Guarantee

If you should move to another country within Europe then your guarantee moves with you to your new home subject to the following qualifications:

- The guarantee starts from the date you first purchased your product.
- The guarantee is for the same period and to the same extent for labour and parts as exists in the new country of use for this brand or range of products.
- This guarantee relates to you and cannot be transferred to another user.
- Your new home is within the European Community (EC) or European free Trade Area.
- The product is installed and used in accordance with our instructions and is only used domestically, i.e. a normal household.
- The product is installed taking into account regulations in your new country.

Before you move please contact your nearest Customer Care centre, listed below, to give them details of your new home. They will then ensure that the local service Organisation is aware of your move and able to look after you and your appliances.

France	Senlis	+33 (0)3 44 62 28 28
Germany	Nurnberg	+49 (0)911 323 2600
Italy	Pordenone	+39 (0)1678 47053
Sweden	Stockholm	+46 (0)20 78 77 50
UK	Slough	+44 (0)1753 219898







**This file has been downloaded from:**

[www.UsersManualGuide.com](http://www.UsersManualGuide.com)

User Manual and User Guide for many equipments like mobile phones, photo cameras, mother board, monitors, software, tv, dvd, and othes..

Manual users, user manuals, user guide manual, owners manual, instruction manual, manual owner, manual owner's, manual guide, manual operation, operating manual, user's manual, operating instructions, manual operators, manual operator, manual product, documentation manual, user maintenance, brochure, user reference, pdf manual